



August 2023
Interim Version

+ RibRaft®

TECHNICAL
MANUAL



This updated manual incorporates the latest guidance for H1. It supersedes previous versions of the manual. CodeMark has been applied for but is currently in progress. Foundations designed with edge insulation and or underslab insulation require a PS1 from a chartered professional engineer until the expected CodeMark version is available.

The current CodeMark can be used for foundations designed with no additional insulation.



This document contains design and installation information. A variation to any of the information given requires specific engineering design and is hence beyond the scope of this document.

The Firth RibRaft® Floor System can be constructed for all slab-on-ground concrete floors for domestic or residential buildings that fall within the scope of NZS 3604:2011 “Timber Framed Buildings” and Clause 3 “Scope” of Section 1 of this Manual. The design and installation details in this Manual shall be used to design and construct such a floor.

The Firth RibRaft® Floor System is **not** covered by the MBIE Codemark® **although it is currently being reviewed, it is required that** design in accordance with Section 1 and installation in accordance with Section 2 of this Manual and on site verification in accordance with Section 3.

To comply with the Manual does mean that Firth Certified Concrete® must be used.

**THIS
MANUAL
CONSISTS
OF 3
SECTIONS:**

**SECTION
1 DESIGN
INFORMATION**
Contains information
principally useful for
the **specifier** or
building designer

1.0	INTRO	4
2.0	TECHNICAL INFORMATION	4
2.1	Overview	4
2.2	Pods	4
2.3	Steel	4
2.4	Concrete	4
3.0	SCOPE	5
3.1	Structure Limitations	5
3.2	Live Loading	5
3.3	Snow Loading	5
3.4	Dead Loading for Use with This Manual	5
3.5	Foundation Requirement for Different Building Types	6
3.6	Foundation Soils	6
3.7	Flow Diagrams	6
4.0	CONSTRUCTION DETAILS	9
4.1	Pod Layout	9
4.2	Edge Beam Width and Reinforcement	9
4.3	Internal Ribs (non load bearing) Width and Reinforcement	9
4.4	Internal Ribs (load bearing) Width and Reinforcement	9
4.5	Point loads	10
4.6	Mesh Reinforcement	11
4.7	Re-entrant Corners	11
4.8	Wingwalls	11
4.9	Bottom Plate Anchors	12
5.0	LATERAL RESISTANCE	13
5.1	Earthquake Resistance	13
5.2	Wind Resistance	14
5.3	Shear Keys	14
5.4	Design Example for Lateral Resistance Calculation	15
6.0	OTHER DESIGN DETAILS	15
6.1	R-Values	15
6.2	Shrinkage Control	17
6.3	Saw Cut Joints	17
6.4	Free Joints	17
6.5	Services Detailing	18
6.6	Within Slab Running of Services	18
6.7	Under Slab Running of Services	18
6.8	Recesses for Showers	20
6.9	Step Down of up to 600mm in the RibRaft® Floor	22

**SECTION
2 INSTALLATION
INFORMATION**
Primarily aimed at the
installer of Firth RibRaft
Floor systems

1.0	INTRO	23
2.0	SITE REQUIREMENTS	23
2.1	General	23
2.2	Temporary Excavations	23
2.3	Surface Water	23
3.0	INSTALLATION PROCEDURE	25
3.1	Site Preparation	25
3.2	Earthworks	25
3.3	Shear Keys	25
3.4	Plumbing and Services	25
3.5	Sand Blinding	26
3.6	Damp Proof Membrane	26
3.7	Edge Formwork	26
3.8	Laying the Pods and Spacers	27
3.9	Reinforcing Steel	27
3.10	Edge Beam Steel	28
3.11	Rib Steel	28
3.12	Mesh Reinforcing	28
3.13	Re-entrant Corner Steel	28
3.14	Concrete Installation	28
3.15	Placing	29
3.16	Finishing	30
3.17	Curing	30
3.18	Shrinkage Control Joints	30
3.19	Saw Cut Joints	30
3.20	Free joints	31
3.21	Removal of Formwork	31
3.22	Masonry Veneer	31
3.23	Landscaping/Paving	31
3.24	Ongoing Maintenance	31
4.0	SHEAR KEYS	32

**SECTION
3 VERIFICATION**
Describes the required
verification checks

1.0	DESIGN	33
2.0	CONSTRUCTION	33

SECTION: DESIGN INFORMATION

1

1.0 THIS SECTION OF THIS MANUAL CONTAINS DESIGN INFORMATION FOR THE FIRTH RIBRAFT® FLOOR SYSTEM (THE SYSTEM). FULL INFORMATION ON THE INSTALLATION PROCEDURES IS DESCRIBED IN SECTION 2: INSTALLATION INFORMATION. WHERE STANDARDS ARE REFERENCED IN THIS MANUAL, THESE SHALL INCLUDE THE LATEST AMENDMENTS.

Notes: 1. Additional admixtures to standard RibRaft® mixes to be approved by the Firth Plant Engineer. 2. Firth concrete mixes are generally formulated to have a **lower carbon footprint**, typically EC10* or greater. Options for additional carbon reduction (greater EC rating) are available on request.

Footnote: *For explanation of the EC rating system, refer to Firth's EPD for concrete.

2.0 TECHNICAL INFORMATION

2.1 Overview

The Firth RibRaft® Floor System is a reinforced concrete waffle raft floor slab-on-ground. Typically it consists of an 85mm thick slab supported by a grid of ribs normally 100mm wide at 1200mm x 1200mm centres. The overall depth is 305-410mm depending on the thickness of the pods and topping. Edge beams and ribs under load bearing walls are 300mm wide to provide for the extra load carried by these members. Where heating coils of less than 25mm diameter are embedded in the topping, the slab concrete thickness shall be 110mm. Where the top floor surface is honed to provide a decorative finish, a slab thickness of 100mm (before honing) should be specified.

2.2 Pods

Firth RibRaft® polystyrene pods 1100mm square and 220mm thick are placed directly on levelled ground and are arranged in such a way as to form a reinforced concrete floor slab with a grid of reinforced concrete ribs and edge beams when concrete is placed onto them. Pods may be cut to suit specific architecture layout and also to accommodate services. 300mm thick pods are available if needed for deeper edge beams and internal ribs, and when greater insulation is required. An alternative to the 220mm thick polystyrene pods is the Cleva Pods® which is a similarly dimension pod made from recycled plastic.

2.3 Steel

Reinforcing mesh in the slab shall consist of Welded Reinforcing Mesh complying with AS/NZS 4671:2019 with a minimum weight of 2.27kg/m², a lower characteristic stress of 500MPa, square configuration of orthogonal bars between 150 to 200mm centres, and ductility class L or E, hereafter referred to "mesh". The presence of Class E or N reinforcing bars in the ribs and beams provides adequate ductility of the system which allows the use of class L mesh. Typically the topping mesh reinforcement will be 665 mesh (class L) or SE62 ductile mesh, each being equally applicable. The reinforcing bars in the ribs and edge beams shall conform to AS/NZS 4671:2019 "Steel Reinforcing Materials". Specifically designed spacers are used to position the polystyrene pods and the rib and edge beam reinforcing steel bars in a secure manner until the concrete is placed. The reinforcing mesh is held in place by mesh chairs or Cleva Pods®. Conventional timber or steel formwork is used to form the edge of the slab.

2.4 Concrete

One of the following Firth concrete products shall be used in the system:

- 1) RaftMix® a 20MPa 100mm slump mix available as a pump mix suitable for 100mm pump lines available in either a 13mm or more usually a 19mm nominal aggregate size, or as a structural (non-pump) mix. For Cleva Pod® use Firth 20MPa (mix code: RC2019AW).
- 2) RaftMix® 25: a 25MPa 100mm slump mix available as a pump mix suitable for 100mm pump lines available in either a 13mm or more usually a 19mm nominal aggregate size, or as a structural (non-pump) mix. This mix shall be specified for buildings constructed in the 'sea spray zone' (i.e. within 500m of the sea including harbours, within 100m of tidal estuaries or inlets, on offshore islands and elsewhere defined as exposure zone D i.in 4.2.3.3 of NZS3604). For Cleva Pod® use Firth 25MPa (mix code: RC2519AW).

2.5 Insulation

For larger area to perimeter ratios (A/P) RibRaft® floors may meet H1 compliance without additional insulation. However, when required, the RibRaft® floor can be insulated with one or more of the following to meet H1 compliance,

- Firth HotEdge® - used for slab edge insulation below masonry veneers.
- Firth HotEdge Extra®, used as a slab edge insulation that sits below 140mm or greater framing.
- Firth HotEdge Base® - used to insulated the underside of the 300mm wide perimeter foundation beam.
- Or in place of HotEdge Base®, insulation below the entire footprint comprising of either 50mm H grade polystyrene or 75mm XPS. 90mm of Slab X 200 polystyrene can be used as an alternative to 75mm XPS.

3.0 SCOPE

This Clause sets out the limitations that apply to the use of the system. Engineering input will be required (PS1) while CodeMark is being updated. The concrete floor slab for buildings or ground conditions that do not meet this scope must be subjected to specific engineering design to comply with the requirements of the New Zealand Building Code.

3.1 Structure Limitations

This manual is applicable where the structure supported by the system complies with the following criteria:

- > The structure supported by the system is constructed in a location where the Seismic Hazard Factor Z (defined in NZ1170.5) is less than or equal to 0.45 (refer to Figure 6).
- > The system is laid level, or has a maximum step of 600mm detailed in accordance with this Manual.
- > The structure supported by the system has no basement, part basement or foundation walls.
- > The total height from the lowest ground level to the highest point of the roof shall not exceed 10m.
- > The structure supported by the system has a roof pitch limited to 60 degrees maximum from the horizontal.
- > The maximum height of a single or top storey is 4.8m and any other storey is 3m.
- > The roof truss span shall be less than or equal to 12m when the roof and ceiling loads are supported entirely by the external walls. Where internal support of roof trusses is used the footings below point loads identified by the truss designer shall comply with this Manual.
- > Where internal load bearing walls are used to support the roof or floors, the loaded dimensions stated in Tables 8.2 and 14.10 of NZS3604:2011 shall apply, and the load bearing wall shall be supported on a 300mm wide load bearing rib as detailed in this Manual.
- > Floors may be of unlimited size provided that the maximum dimension between free joints shall not exceed 30m. Where free joints are required they should be detailed in accordance with this Manual.

3.2 Live Loading

The live loading cases of structures covered by these designs are:

- > 1.5kPa and 3.0kPa as per NZS3604 "Timber Framed Buildings".
- > 13kN concentrated load in garage over area of 0.3 x 0.3m (vehicle limited to 2500kg gross).

3.3 Snow Loading

Open ground snow loading as defined in NZS3604 of up to 2.5kPa.

3.4 Dead Loading for Use with This Manual

The dead load cases of structures covered by these designs are:

- > Light external walls with total mass not exceeding 60kg/m² – e.g. timber framing with weather boards and interior wall linings.
- > Heavy external walls with total mass greater than 60kg/m² but not exceeding 220kg/m² – e.g. timber framing with masonry veneer.
- > Internal walls with total mass not exceeding 45kg/m² – e.g. timber framing and linings.
- > Light roofs with total mass not exceeding 45kg/m² – e.g. ceiling linings and metal roof, including framing.
- > Heavy roofs with total mass greater than 45kg/m² but not exceeding 85kg/m² – e.g. ceiling lining and concrete tiles or slates, including framing.
- > Mid-floors with total mass not exceeding 60kg/m² – e.g. timber framing and flooring, including ceiling linings.
- > Heavy internal walls and/or load bearing internal walls supported on a load bearing rib.

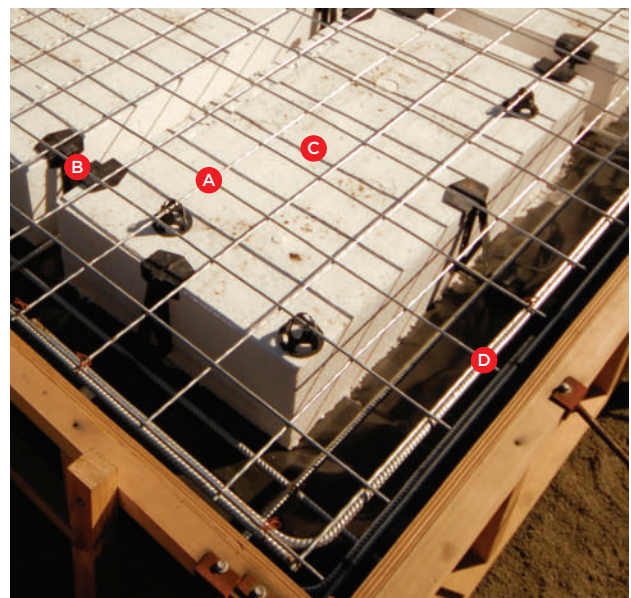

The RibRaft® System

- A** Steel mesh reinforcing
- B** Firth 100mm spacer
- C** Firth RibRaft® polystyrene pods
- D** Steel reinforcing

3.5 Foundation Requirement for Different Building Types

The designs given in this Manual are limited to where the system supports Building Types as described in Table 1. The classification of wall and roof weights are as detailed in Clause 3.4 of this Section. Single and two storey shall be as defined in NZS 3064.

Table 1.
Foundation
Type Identifier

NUMBER OF STORIES	ROOF	GROUND FLOOR EXTERNAL WALLS	SECOND STOREY EXTERNAL WALLS	1.5KPA LIVE LOAD & UP TO 1KPA SNOW LOAD	1.5KPA LIVE LOAD & UP TO 2.5KPA SNOW LOAD	3KPA LIVE LOAD & /OR 2KPA SNOW LOAD
SINGLE STOREY	Light	Light		A	A	A
	Heavy	Light		A	B	B
	Light	Heavy		B	C	B
	Heavy	Heavy		C	D	C
DOUBLE STOREY	Light	Light	Light	C	C	D
	Heavy	Light	Light	D	D	E
	Light	Heavy	Light	D	D	E
	Heavy	Heavy	Light	E	E	G
	Light	Heavy	Heavy	E	E	SED

3.6 Foundation Soils

The system may be used when the supporting ground meets the definitions of “good ground” given in Section 3 of NZS 3604 (as modified by B1 of the Building Compliance Documents). In addition, the system shall not be used for damp sites i.e. where it can be reasonably expected that the ground water level could come within 600mm of the underside of the system. The acceptability of the ground shall be verified in accordance with Clause 3.1.3 of NZS 3604.

Solutions for soils prone to liquefaction or expansive soils are available using the Firth RibRaft® technology, however these are outside the scope of this Manual and require specific engineering design.

Where the ultimate bearing capacity required of the supporting ground is verified by Scala Penetrometer testing in accordance with Clause 3.3 of NZS3604 or for cohesive soils using a calibrated shear vane in accordance with the NZGS Guideline for Hand Held Shear Vane Test, the bearing capacity shall exceed the values in Table 2 for the proposed building type. For scala penetrometer testing, the bearing capacity shall be considered adequate when the number of blows per 300mm depth of penetration below the underside of the system at each test site exceeds the values given in Table 2 below.

For RibRaft® foundations compliance with Table 2 allows ultimate bearing capacities of less than 300kPa. However, with the exception of bearing capacity all other requirements in NZS3604 for “good ground” shall be complied with.

Table 2.
Scala Penetrometer Blows
Required and Ultimate
Bearing Capacity

FOUNDATION TYPE	ULTIMATE BEARING CAPACITY (KPA)	MIN. BLOWS PER 300MM DEPTH FOR SCALA TESTING
A	140	4
B	175	5
C	210	6
D	240	7
E	275	8
G	Good ground	9

3.7 Flow Diagrams

The flow diagrams on the following pages (adapted from NZS3604) will help in determining whether the details for the system can be used for the purposes of the concrete floor slab construction. There are two checks in the process. The first is to determine whether the proposed building complies with the requirements set out in this Manual (Building Check), and the second is to determine whether the site complies with the requirements set out in this Manual (Site Check).

Note: NZS3604 provides for parts of buildings to be considered as individual buildings. These flow diagrams apply to those parts of the building where slab-on-ground is being considered and where the part of the building can be considered as an individual building under NZS3604.

Figure 1. Building Check Flow Diagram

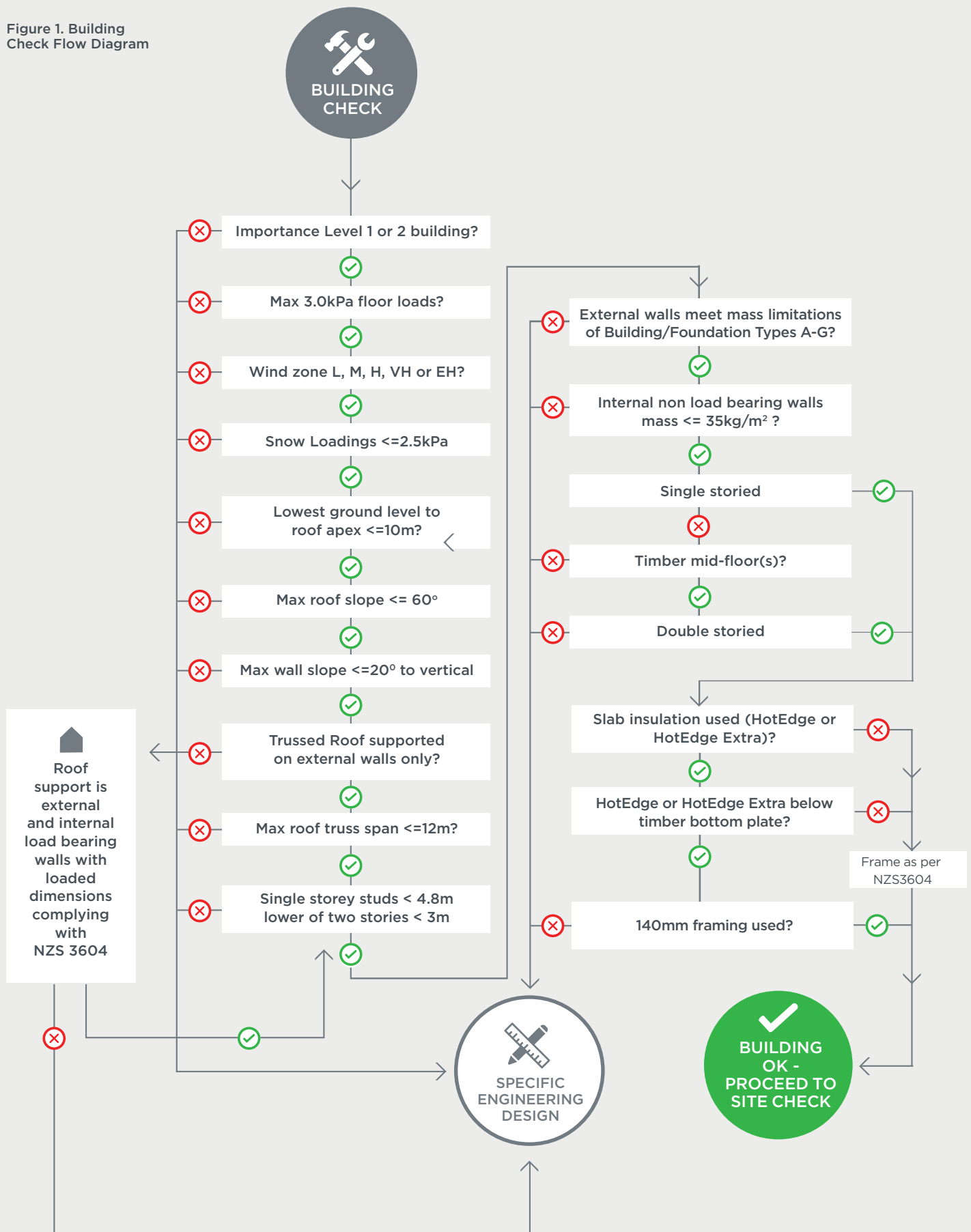
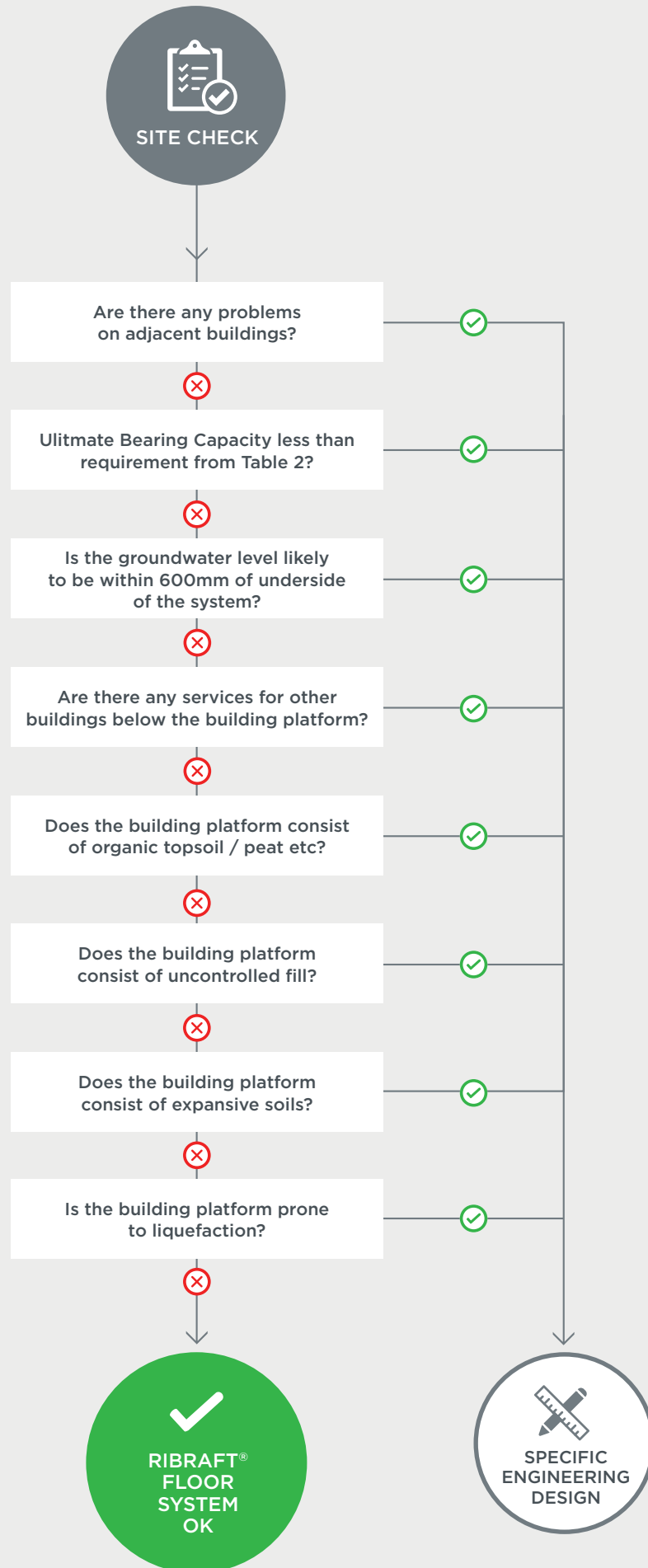

Figure 2. Building Check Flow Diagram



4.0 CONSTRUCTION DETAILS

Standard construction details for the system are provided here for buildings that fall within the scope.

4.1 Pod Layout

RibRaft® polystyrene pods supplied by Firth (1100 x 1100 x 220 or 300mm thick) shall be placed on levelled ground and arranged in a waffle pattern. The pods are used as void formers while the concrete is curing. Cleva Pods® which are plastic pods of 1100 x 1100 x 220mm dimension made of recycled material may be used in place of the polystyrene pods.

Pods shall be placed so that the maximum clear separation from any rib or beam shall not exceed 1.1m. Pods maybe cut down to size but shall not be added to.

Figure 3 shows a typical layout of the pods and ribs. Note the part pods around the edge, where the building shape dictates, and adjacent to the 300mm rib.

Firth suggests that when drawing the building plan, a generic RibRaft® grid (100mm wide ribs at 1200mm centres) is set out using the corner of the building as a starting point. The location of any load bearing ribs, or point loads greater than 10kN, are identified and pods cut to establish 300mm wide ribs or foundation pads as described in this Manual. The most cost effective solution being a simple grid layout which requires minimum cutting of the pods. Ribs can be used at less than 1200mm centres, however it is more cost effective to use the 1200mm centres wherever practicable.

Figure 3. Typical RibRaft® Plan

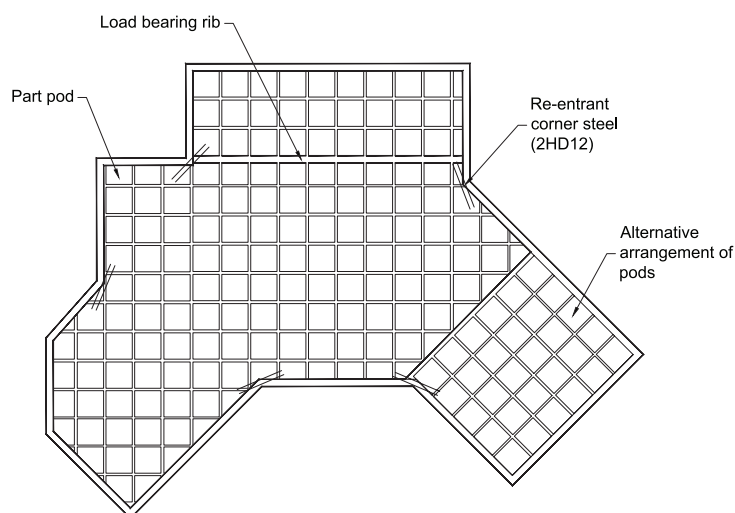

4.2 Edge Beam Width and Reinforcement

Edge beams around the perimeter of the floor slab shall be 300mm concrete thickness to provide bearing capacity for external load bearing walls, and contain 2-HD12 bars (Grade 500E or 500N) as bottom steel and 1-HD12 bar (Grade 500E or N) in the top. This top bar shall be tied to the underside of the reinforcement mesh. Refer Figures 5, below for construction details. The edge beam shall be rebated for brick veneers where necessary as shown in Figures 5C / 5E / 5G.

4.3 Internal Ribs (non load bearing) Width and Reinforcement

Each standard internal rib shall be 100mm wide and shall contain 1-HD12 steel bar (Grade 500E or N) held in place at the bottom of the rib by a Firth spacer. Refer Figure 5A for construction details.

4.4 Internal Ribs (load bearing) Width and Reinforcement

For all load bearing walls and heavy internal walls, the pods shall be cut to create a 300mm wide rib directly under the load bearing wall, with 2-HD12 (Grade 500E or N) steel bars as bottom steel. Refer Figure 4B for construction details under load bearing walls. Where the load bearing ribs meet and terminate at an edge beam or internal rib the bottom reinforcement from the load bearing rib shall be bent into the adjacent rib and tied together. The reinforcement shall lap for at least 720mm.

4.5 Point Loads

Truss manufacturers often support the roof trusses internally which are described on the truss manufactures drawings as falling into various ultimate limit state categories. Table 3 summaries when individual footings are required below the reactions, and the form these should take.

Table 3. Foundation Requirements for Individual Point Loads

FOUNDATION OPTIONS BELOW POINT LOAD:

ULTIMATE LIMIT POINT LOAD REACTION	BEAM OPTION, BEARING CAPACITY GREATER THAN 140KPA ⁽¹⁾
Up to 10kN	No thickening required
Up to 20 kN	300mm wide load under point load as detailed in Figure 4A
Up to 30kN	300mm wide load under point load as detailed in Figure 4A

Notes:

(1) Refer section 3.6 for confirmation of bearing capacity. With exception of bearing capacity all other requirements in NZS3604 for good ground shall be complied with.

Table 4 Details for Beam Option Thickening Under Point Loads

ULTIMATE LIMIT LOAD P FROM TRUSS DESIGNER	MINIMUM EDGE DISTANCE X IN MM
20kN	200 *
30 kN	400 *

* If minimum edge distances cannot be achieved extend thickening to next 100mm ribs

Figure 4A.

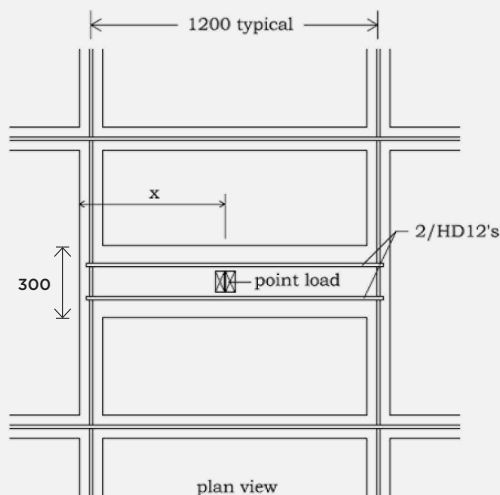
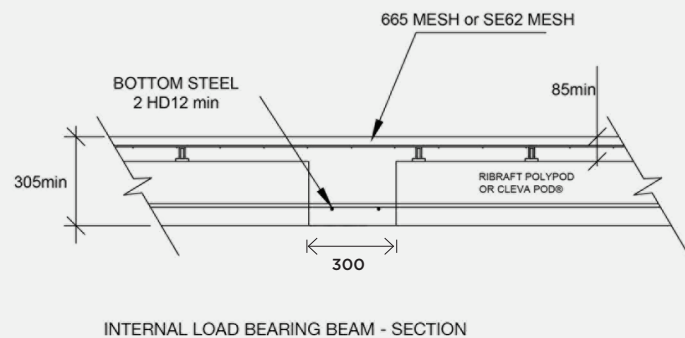

Figure 4B.



4.6 Mesh Reinforcement

The entire floor slab shall be reinforced with 665 or SE62 mesh supported on mesh chairs to achieve a minimum of 30mm cover to the top surface sitting on the polystyrene or Cleva Pods®.

4.7 Re-entrant Corners

In order to limit the width of cracking at the re-entrant, or internal corners, extra steel shall be placed on top of the mesh. These shall be 2-HD12 bars (Grade 500E or N), 1200mm long tied to the top of the mesh at 200mm centres, with 50mm cover from the internal corner – refer Figure 3.

4.8 Wingwalls

Non Load bearing wingwalls up to 600mm in length can be accommodated as detailed in this manual. The timber framing of the wingwall shall be latterly supported at floor levels and at the eaves. Load bearing wingwalls and wingwalls greater than 600mm or not supported laterally at eaves and floor level will require SED. See construction details refer Figure 12E.

Figure 5. Standard RibRaft® Construction Details

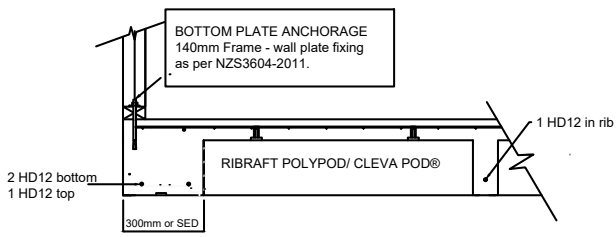

A 220mm FIRTH RIBRAFT POLYPOD/ CLEVA POD®
90mm WALL FRAME- NO INSULATION
FIRTH RAFTMIX 20 OR 25MPa

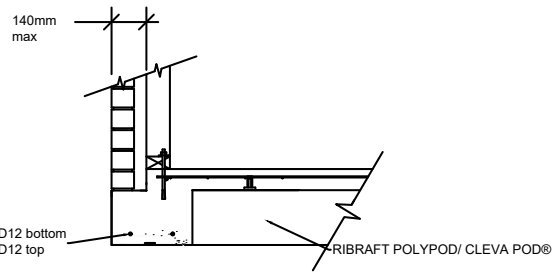

E 220mm FIRTH RIBRAFT POLYPOD/ CLEVA POD®
BRICK VENEER - NO INSULATION
FIRTH RAFTMIX 20 OR 25MPa

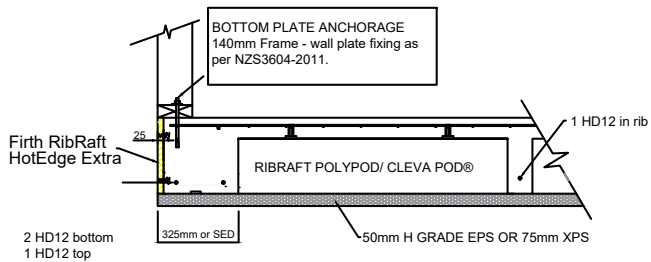

B 220mm FIRTH RIBRAFT® POLYPOD/ CLEVA POD®
140mm WALL FRAME HOTEDGE EXTRA® & UNDERSLAB INSULATION
FIRTH RAFTMIX 20 OR 25MPa

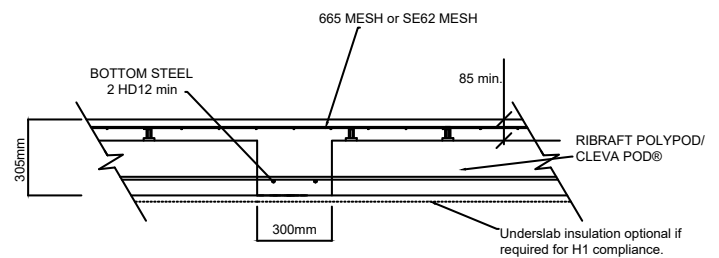

F 220mm FIRTH RIBRAFT POLYPOD/ CLEVA POD®
140mm WALL FRAME HOTEDGE EXTRA & UNDERSLAB INSULATION
FIRTH RAFTMIX 20 OR 25MPa

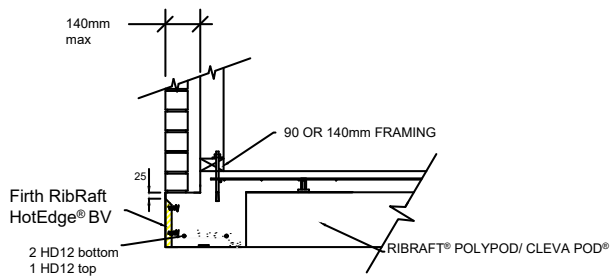

C 220mm FIRTH RIBRAFT POLYPOD/ CLEVA POD®
BRICK VENEER HOTEDGE® (BV)
FIRTH RAFTMIX 20 OR 25MPa

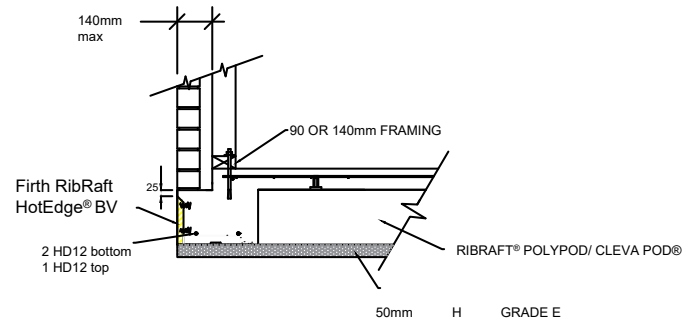

G 220mm FIRTH RIBRAFT® POLYPOD/ CLEVA POD®
BRICK VENEER HOTEDGE® & UNDERSLAB INSULATION FIRTH
RAFTMIX 20 OR 25MPa

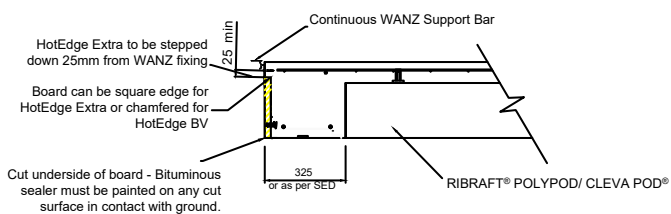

D FIRTH RIBRAFT HOTEDGE JOINERY DETAIL

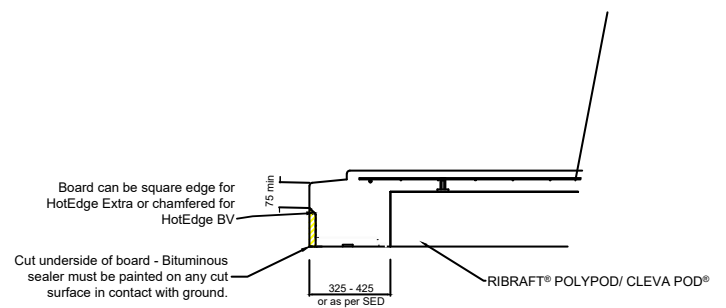

H GARAGE DOOR STEP CONSTRUCTION DETAIL

5.1 Earthquake Resistance

Unlike conventional foundation systems, the Firth RibRaft® system is not embedded into the ground. Sliding resistance to horizontal seismic loads is provided by frictional contact with the soil. In locations where the Seismic Hazard Factor Z is greater than 0.45, shear keys maybe required to resist seismic loads. Such buildings require specific engineering design and are outside the scope of this document. Refer to Figure 6.

Depending on the wind zone and the weight of the building elements this frictional resistance may not be sufficient to provide sliding resistance to wind loads, and specific shear keys may be required, as detailed in Clause 5.2.

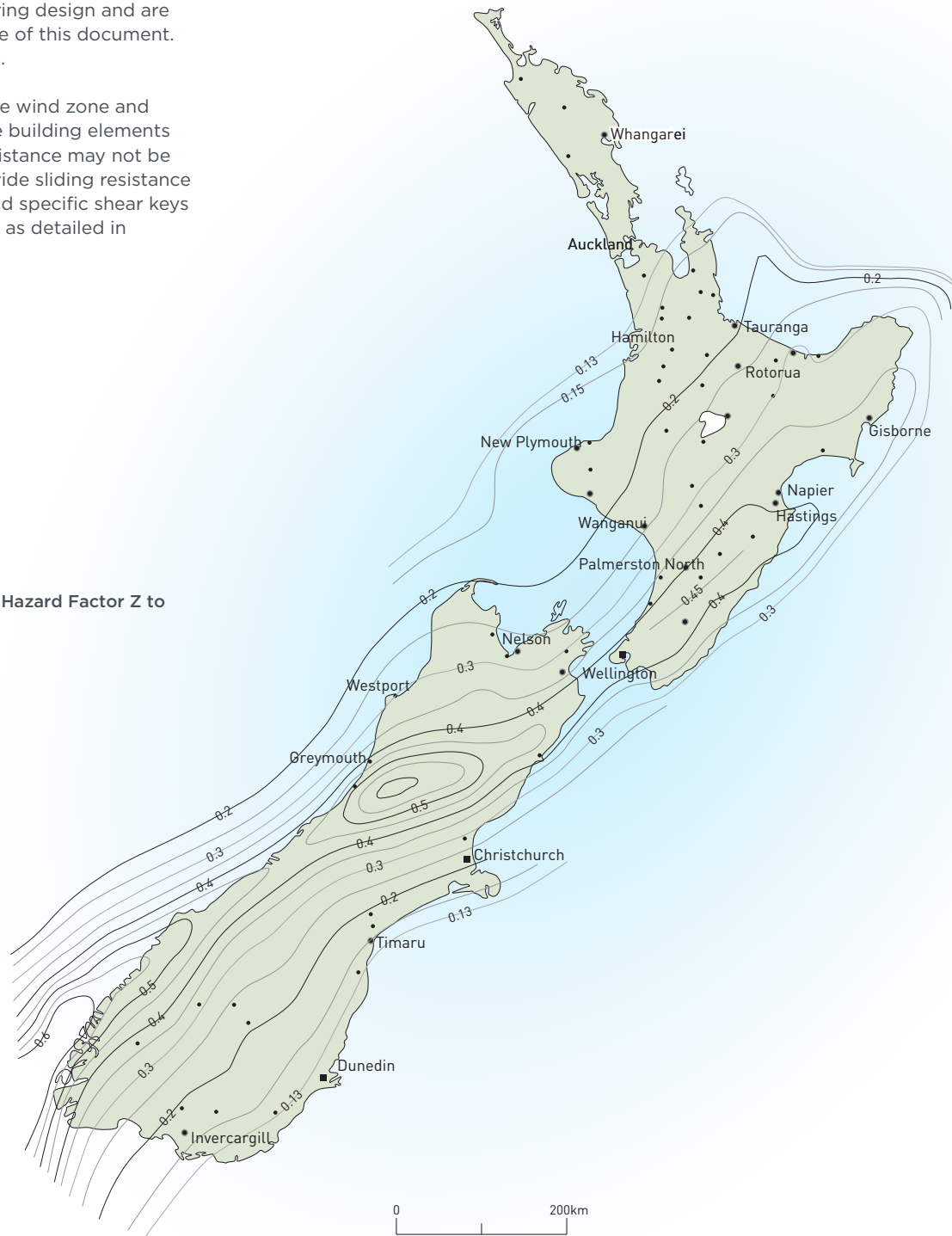

Figure 6. Seismic Hazard Factor Z to NZS 1170.5



5.2 Wind Resistance

The building's bracing demand from wind loading shall be assessed from Section 5 of NZS 3604 for both directions (i.e. along and across the building). The bracing capacity of the system must exceed the greater of the bracing demands determined.

The bracing capacity of the system shall be determined as the sum of the bracing capacity provided by frictional resistance (i.e. friction between the system and the ground) and the bracing capacity provided by the shear keys (if any) necessary to meet the requirements of Clause 5.2.

The bracing capacity provided by frictional resistance shall be determined from Table 4 depending on the building type, roof weight, and floor live loading. The bracing capacity provided by the shear keys shall be the sum of the bracing capacity of the individual shear keys determined as follows. If the shear key is in clay, each shear key shall be considered to contribute 170 BU's. If the shear key is in sand, each shear key shall be considered to contribute 200 BU's. If the bracing capacity of the system, determined from the frictional resistance and the shear keys as described above, is less than the bracing demand further shear keys shall be added until the bracing demand is met.

Table 4. Bracing Capacity Provided By Frictional Resistance Per 100m² Of Ground Floor Area

BUILDING TYPE	ROOF TYPE	GROUND FLOOR EXTERNAL WALLS	SECOND STOREY EXTERNAL WALLS	BU's PROVIDED PER 100M ² 1.5KPA	FOR LIVE LOADING OF: 3.0KPA
Single Storey	Light	Light		1630	1746
Single Storey	Heavy	Light		1737	1857
Single Storey	Light	Heavy		1802	1922
Single Storey	Heavy	Heavy		1909	2029
Double Storey	Light	Light	Light	2163	2403
Double Storey	Heavy	Light	Light	2270	2510
Double Storey	Light	Heavy	Light	2335	2575
Double Storey	Heavy	Heavy	Light	2442	2682
Double Storey	Light	Heavy	Heavy	2524	2764

5.3 Shear Keys

Shear key piles required by Clause 5.2 must be uniformly distributed around the perimeter of the building, and be located at the edge beam/internal rib junction. Where a shear key is required, the minimum number of shear keys shall be two per floor plan. Where two shear keys are used they shall be placed at diagonally opposite ends of the floor plan.

Construction details of the shear keys shall be as shown on Figure 7. Shear keys shall be a minimum of 900mm long. The holes shall be over-drilled at least 100mm and a polystyrene RibRaft® Shear Key Support placed into the bottom of each hole. This will support only the plastic (wet) concrete and then allow movement of the shear key if settlement of the supporting ground occurs. The effective end bearing of the shear keys is therefore eliminated.

Figure 7. RibRaft® Shear Key

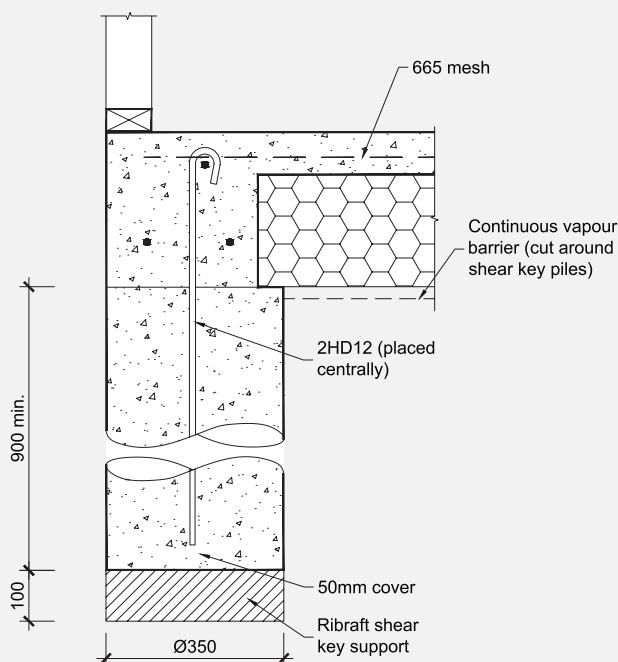

5.4 Design Example For Lateral Resistance Calculation

The following is a short example to demonstrate the process of determining whether shear piles are required.

Consider a 180m² single storey home with a light roof located in Palmerston North in a VH wind zone as defined by NZS3604. Assume the building height is 6m with 3m above the eaves. The length for across wind considerations is 15m and the width (along wind) is 12m.

First consider seismic actions. From Figure 6 the seismic hazard factor is 0.4. Since this is less than 0.45 shear keys will not be required for earthquake resistance.

Now consider wind loading. Table 5.5 of NZS3604 requires 95 bracing units per meter (BU/m) across the building and 90 BU/m along. As it's a very high wind zone these figures need to be increased by a factor of 1.3.

The BU demand for across building wind is therefore = 95 x 1.3 x 15 = 1853BU
The BU demand along the building = 90 x 1.3 x 12 = 1404BU

From Table 4 for a single storey light weight roof with 1.5kPa live load the capacity is 1630BU per 100m². Therefore for 180m² the capacity is 2934BU. As the capacity (2934) is greater than the demand (1853) no shear keys are required.

If the demand had exceeded the capacity then any shortfall can be provided by supplying shear keys in accordance with Section 5.3 with each shear key providing the BU specified in Section 5.2.

6.0 OTHER DESIGN DETAILS

6.1 R-Values

The insulation performance of a building element is measured by the "R-Value". Recent revisions to clause H1 of the Building Code has significantly changed the method used to calculate the insulation values of slabs supported on the ground. The most significant change being that the ground is now assumed to have a default thermal conductivity of 2 W/(m.K) (more conductive than previously assumed) and modelling of the floor units are conducted in accordance with ISO 13370. The information provided in the R Value calculator have been developed using method described in H1/VM1.

A further subtle change is that the way the area to perimeter ratio is calculated (A/P ratio). H1/AS1 defines this as:

$$\text{slab area to perimeter ratio } \left(\frac{A}{P}\right) = \frac{A_{slab,internal}}{P_{slab,internal}}$$

Alternatively, where external dimensions are known the following can be used.

$$\text{slab area to perimeter ratio } \left(\frac{A}{P}\right) = \frac{A_{slab,external}}{P_{slab,external}} - \frac{w}{2}$$

Where w equals the horizontal distance between the slab edge and the interior surface of the wall.

The acceptable solutions for H1, provides 3 methods of demonstrating compliance with the Building Code requirements. These being:

- The schedule method
- The calculation method
- Modelling using H1-VM1

H1 now splits New Zealand into 6 climate zones. Compliance by the schedule method involves providing a solution with a calculated R value in excess of the minimum scheduled value for the relevant climate zone. Tabled below are the minimum required R values for slabs on ground

BUILDING ELEMENT	CONSTRUCTION R VALUES (M2.K/W)					
	Zone 1	Zone 2	Zone 3	Zone 4	Zone 5	Zone 6
Slab on ground	R1.5	R1.5	R1.5	R1.5	R1.6	R1.7
Slabs on ground with embedded heating coils	R2.5	R2.5	R2.5	R2.8	R3.0	R3.0

New Zealand Climate Zones

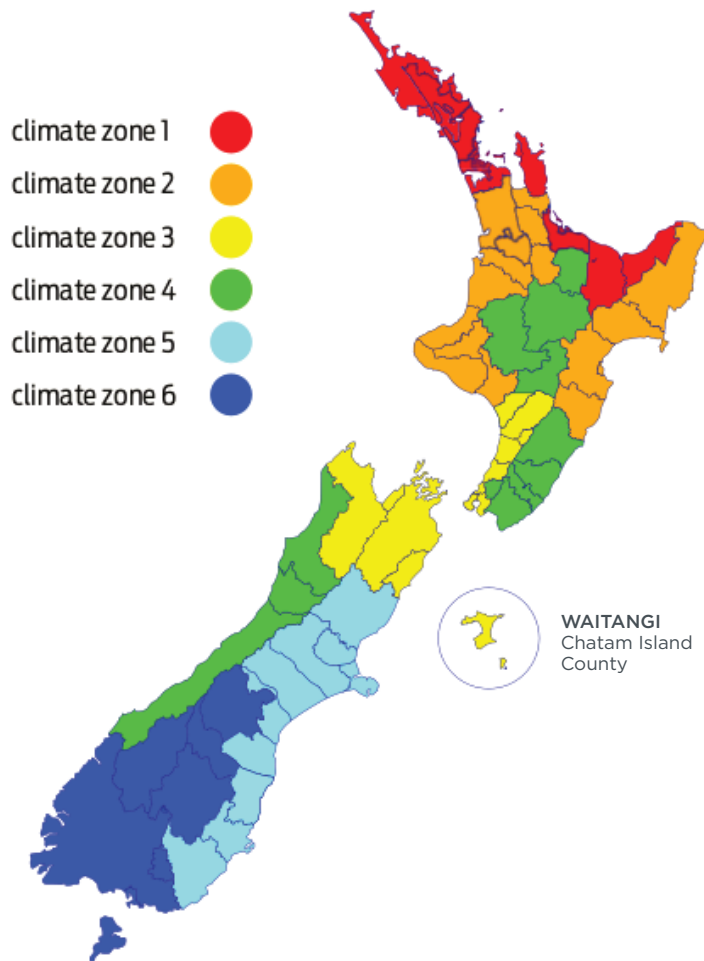

The Firth HotEdge® range provides a suite of products to achieve compliance with the minimum R-values stipulated by the H1 schedule method. The construction R-values for the various Firth solutions can be found by using the R-value calculator at www.firth.co.nz/r-value-calc/

The calculation method described within H1 allows, optimised solutions to be developed by offsetting R-values within different elements of the building. Refer to H1 for details. There is a requirement that the R-values are not reduced by more than 50% of the Schedule Method. The exception being floors containing heating elements. For heated floors the R-values cannot be reduced below those specified in the schedule method. To conduct comparisons between the heat loss of the reference building and the proposed structure requires information on the actual R-value of the flooring system.

6.2 Shrinkage Control

Shrinkage control joints reduce the risk of unwanted cracks, and their placement needs to be carefully considered where uncontrolled cracking could be unacceptable. Two types are described here: saw cut joints (which are tied joints), and free joints.

6.3 Saw Cut Joints

Saw cuts are located at positions in which the concrete is likely to crack due to stresses induced by restrained shrinkage. The aim of providing them is for the concrete to crack at the bottom of the saw cut thus minimizing the potential for a visible crack wandering over the surface. The level of reinforcement provided in a RibRaft® mean that cracks have no structural implications (ie Building Code compliance) being only an aesthetics issue. Therefore saw cuts are not mandatory for B1 compliance. Factors to consider are the type of floor finish, the location of ribs and ground beams, underfloor heating, and the effect of piles restraining shrinkage.

Preference should be given to using early entry saws which are used immediately after finishing. Shrinkage control joints cut using diamond blades shall be cut as early as possible which is typically within 24 hours of hardening in summer, and 48 hours in winter. They shall be cut to a depth of 25mm. Shrinkage control joints do not guarantee elimination of all visible or unwanted cracks but should minimise the number.

Joints shall be positioned to coincide with major changes in floor plan. Where concrete is to be exposed, for example in a garage, or brittle covering placed over, the maximum intermediate bay sizes should be limited to 5m. Bay dimensions formed by shrinkage control joints shall be limited to a maximum ratio of length:width of 1.5:1. Shrinkage control joints shall be placed over 100mm wide internal ribs wherever possible. Where a shrinkage control joint runs along the line of a 300mm wide load bearing rib, then the joint shall be located directly above one edge of that rib.

In order to limit the width of cracks at re-entrant, or internal corners, extra steel shall be placed on top of the mesh. These shall be 2-HD12 bars (Grade 500E or N), 1200mm long tied to the top of the mesh at 200mm centres, with 50mm cover to the internal corner - refer Figure 3.

6.4 Free Joints

Where the length of the floor exceeds 30m a free joint shall be provided as detailed in Figure 8. Movement, shrinkage and thermal, will occur over this joint so it shall be positioned to minimize the impact of this movement on floor coverings and wall elements.

Where the bottom of the RibRaft® is not flat (for example the floor incorporates a step down), free joints shall be provided if the distance from the step down to edge of slab exceeds 15m.

Figure 8. Free Joint Details

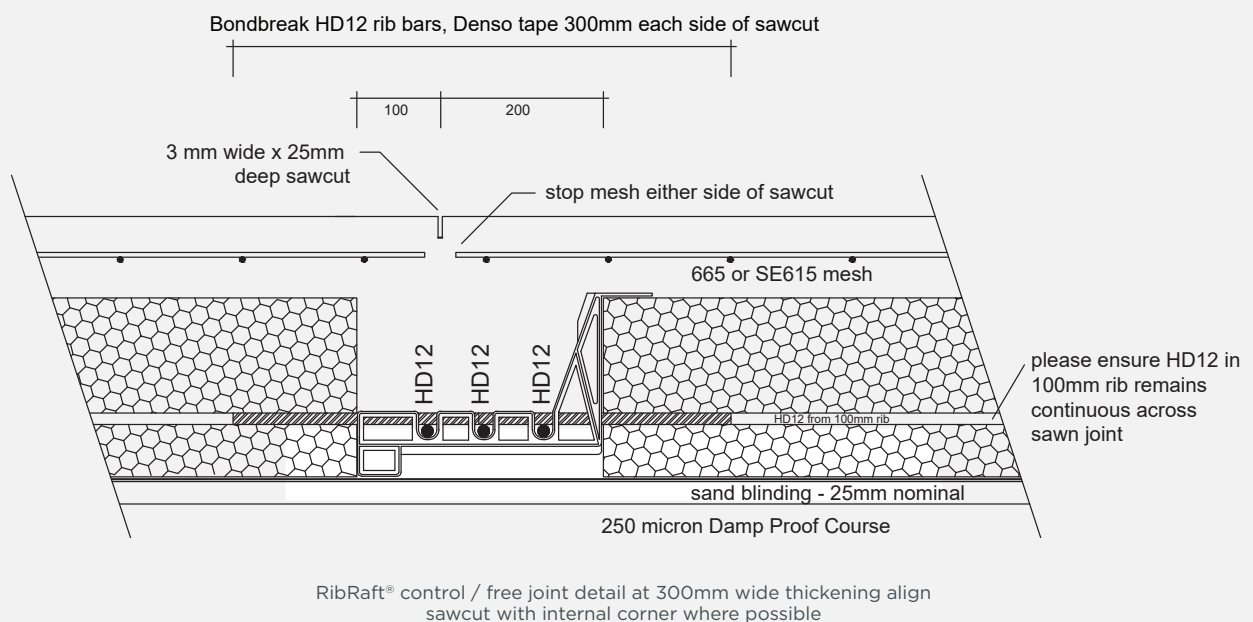

6.5 Services Detailing

Two options exist for running services, both of which are appropriate, however some regional Building Consent Authorities and Builders have clear preferences. The options being within slab, or under slab. Experience from the Christchurch earthquakes shows that the most seismically robust solution is for services to run within the plane of the pods (within slab).

6.6 Within Slab Running of Services

Pipes services can be run within the plane of the pods either exiting out of the side of the perimeter ring beam or going underground at the edge beam. Pipes shall be laid at a fall to comply with NZBC G13/AS1. For pipe up to 65mm diameter the minimum gradient is typically 1 in 40, while for 100mm pipes it's 1 in 60, however greater falls may be required dependent upon the required number of discharge units. Table 5 provides distances from the edge of the slab to pipe surface penetration to achieve minimum pipe gradients. A 300mm pod alternative is often used where the proposed positioning of the service means minimum required gradients cannot be achieved. Where gradients cannot be achieved with a 300mm pod, then service will require to be run under the slab.

Pipes shall be located to pass perpendicular to the ribs and beams and shall not be laid along the length of ribs or beams. Pods are cut as required to achieve the required fall and position. Pipes shall be laid to ensure 15mm concrete cover between pipe and reinforcement in the perimeter beam. All pipes in contact with concrete shall be lagged with an impermeable material of at least 6mm thickness.

Table 5. Maximum Distance From Exterior To Entrance Point Of Plumbing Pipes

PIPE DIAMETER (ID)MM	GRADIENT	MAXIMUM DISTANCE TO EDGE WITH 220MM THICK POD	MAXIMUM DISTANCE TO EDGE WITH 300MM THICK POD
40	1 in 40	3400	6600
50	1 in 40	3000	6200
65	1 in 40	2400	5600
100	1 in 60	1200	4400

6.7 Under Slab Running Of Services

For this option, services ducts shall be conveyed underground to their plan location then brought up through the polystyrene or plastic pod and the concrete floor slab, within the limitation imposed by Table 6. Services shall not be placed within any concrete except to cross that section of concrete i.e. services shall not run along ribs or edge beams. In accordance with AS/NZS3500.5:2015 pipes penetrating through concrete shall be:

- > Installed at right angles to the slab surface.
- > Lagged with an impermeable material for the full depth of the concrete penetration.
- > Lagging must be at least 6mm thick.

The maximum diameter of the services shall be as outlined in Table 6.

Any services crossing ribs or the edge beam horizontally shall be placed only within the middle third of the member. Except as noted in Figure 9, services crossing the ribs vertically shall also be constrained to the middle third of the width of the edge or internal load bearing rib. Except as noted in Figure 10 at no stage shall any of the reinforcement bars be relocated or cut to allow for the services (it is acceptable, however to cut the mesh). In some instances this will dictate the location of the ribs. The pods shall be cut to allow for this and if necessary, the spacing of the ribs shall be decreased locally. There shall be 600mm minimum clear spacing in each direction between penetrations through the system.

Table 6. Maximum Diameter Of Pipe Services

ELEMENT	VERTICAL SERVICE	HORIZONTAL SERVICE
300mm wide edge beam	50mm nominal bore pipe	100mm NB pipe
500mm localized wide edge beam (1)	100mm NB pipe	100mm NB pipe
300mm wide internal load bearing rib	50 NB pipe	100mm NB pipe
100mm wide internal rib	Nil	100mm NB pipe
Slab	100 NB pipe, or for large services 450mm square see also Note 3	Nil

Notes:

- (1) For situations where a 100mm diameter pipe is required to pass vertically through the edge beam or internal load bearing beam, the beam shall be locally increased in width to a minimum of 500mm wide. This shall be achieved by keeping flush the outside face of the edge beam and removing 200mm from the pod. The width shall remain at 500mm for a distance of 600mm beyond the service pipe. Refer to figure 14 for details for pipes passing vertically through beams and internal ribs.
- (2) Where a gas pipe line runs through the RibRaft® floor system, in addition to the requirements above, the pipeline shall enter the building through the outside face of the perimeter foundation beam, be concrete encased and located in the plane of the pods. The aim being to ensure that damage to the gas pipe will most likely occur outside the building envelope should movement occur between the ground and RibRaft® in a large earthquake.
- (3) Larger penetrations or voids up to 450mm square (e.g. for shower waste/traps) are permitted through the slab provided all the conditions of this paragraph are met. These openings shall be trimmed with 1 HD12 (Grade 500E or N) bar 1500mm long placed along each side of the opening, tied to the mesh. One set of parallel bars shall be placed on top of the mesh and the other set placed under the mesh. These openings shall not be placed over a rib or edge beam. If necessary, the rib spacing shall be reduced or the pod layout altered to ensure that the opening occurs solely in the slab above a polystyrene pod. Penetrations such as these shall not be installed in garages or other areas where large (>3kN) point loads could be present. Only one penetration greater than 120mm is permitted in the slab above any single pod or part pod. Where two large openings are required to be in close proximity, an internal rib shall separate them. For these large penetrations/voids in the slab, the services shall not be within 25mm of the edges of the void through which they pass, and the opening shall be sealed to prevent materials entering the subfloor cavities. (This type of opening is normally only required for a shower waste/trap and the installation of the shower will ensure that the void is sealed/covered).

A pictorial of some of the above requirements is illustrated in Figure 9 and 10.

Figure 9. Example of Detailing Requirements For Services

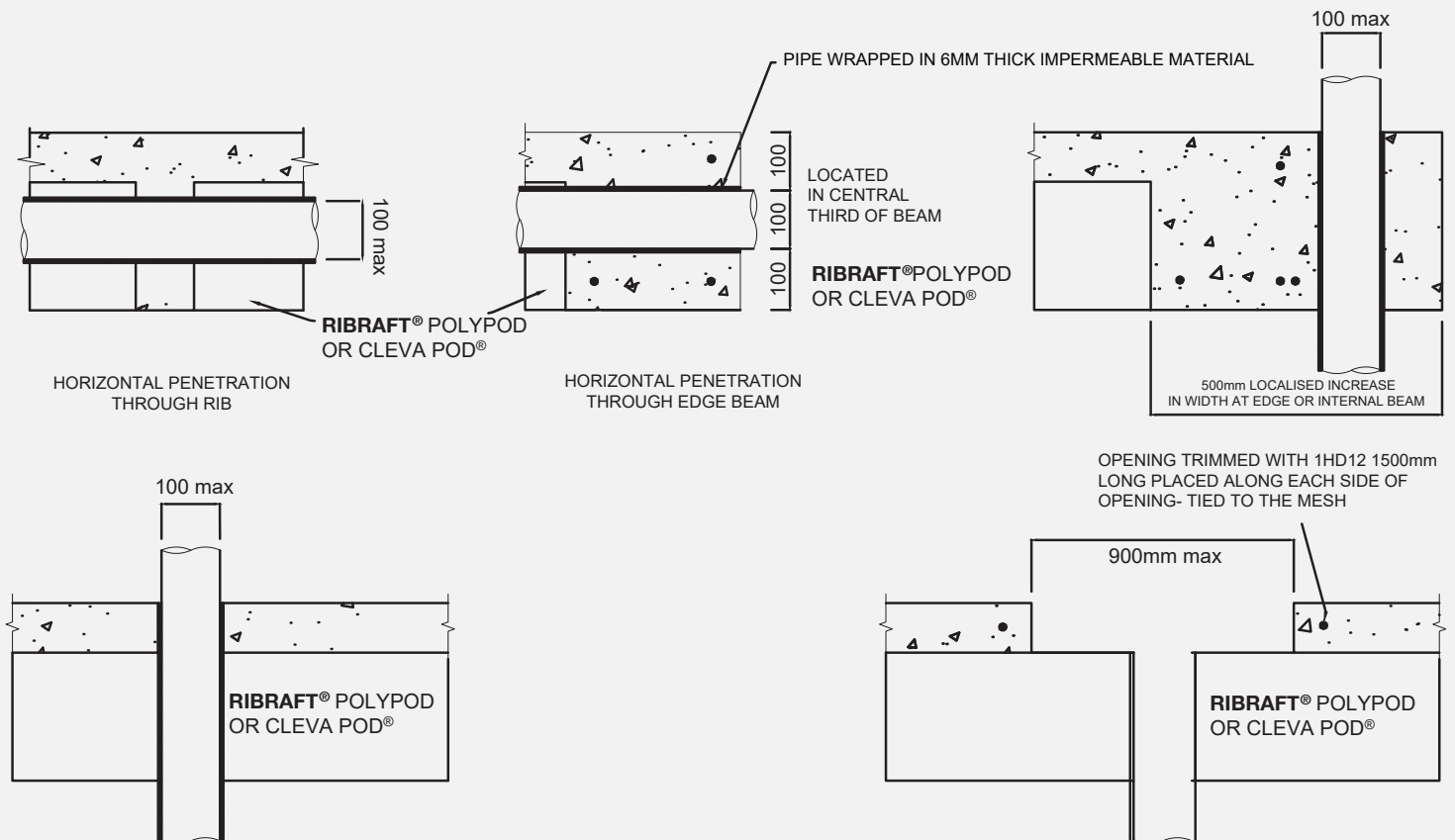
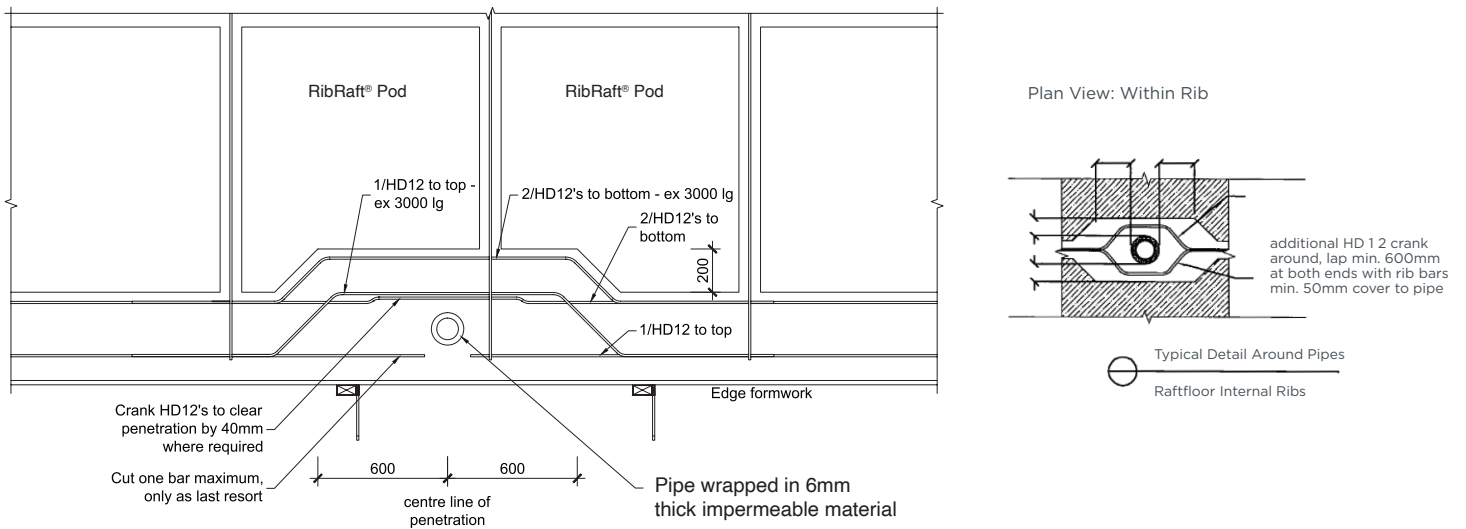

Figure 10. Localised Increase In Width At Edge Beam Where Vertical Service Up To 100mm Diameter Are Required



6.8 Recesses for Showers

Where showers are rebated up to 50mm into the RibRaft® concrete topping, the details specified shall be in accordance with Figure 11.

Figure 11. Details where recesses of up to 50mm are required for rebated showers

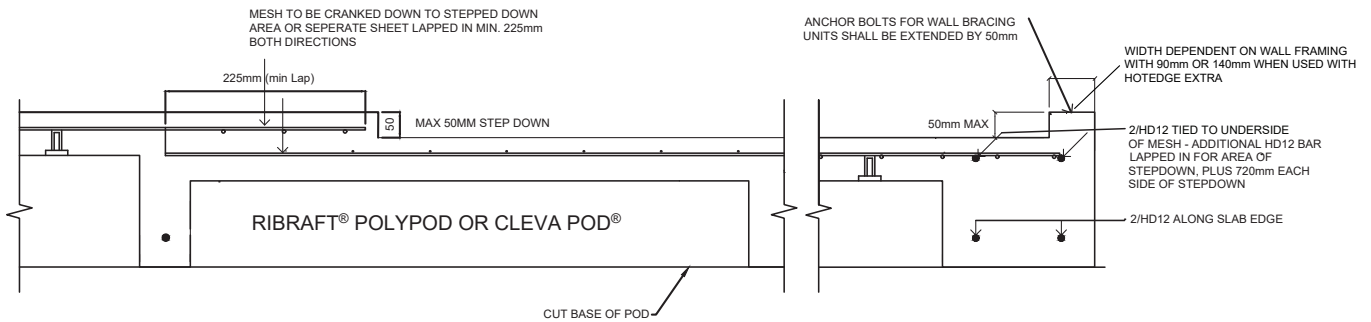

RIBRAFT® FLOOR - SET-DOWN DETAIL FOR MAX. 50mm REBATED SHOWER

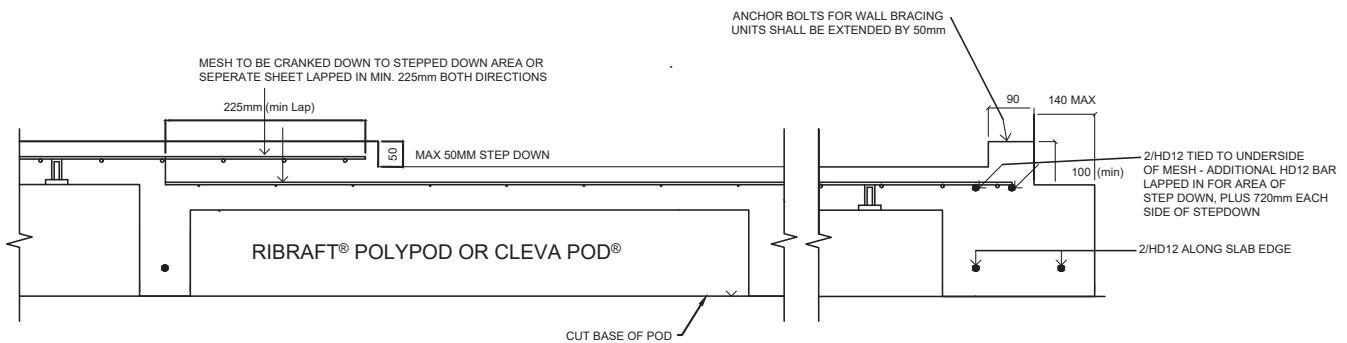

RIBRAFT® FLOOR - SET-DOWN DETAIL FOR MAX. 50mm REBATED SHOWER- BRICK REBATE

Figure 12. Construction Details

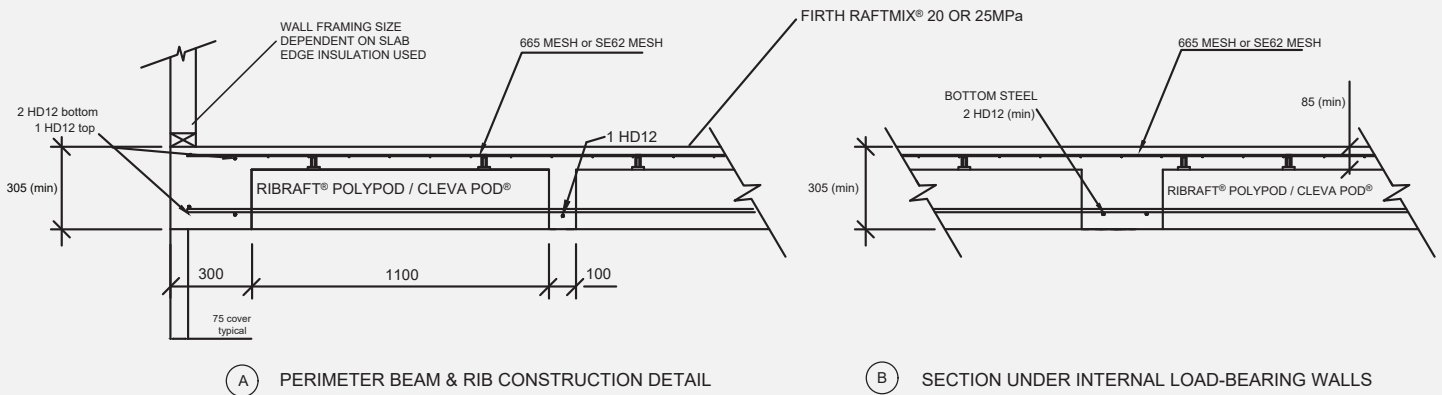

Note: Slab edge and underfloor insulation not shown for clarity, refer figure 5 also when combining with insulation.

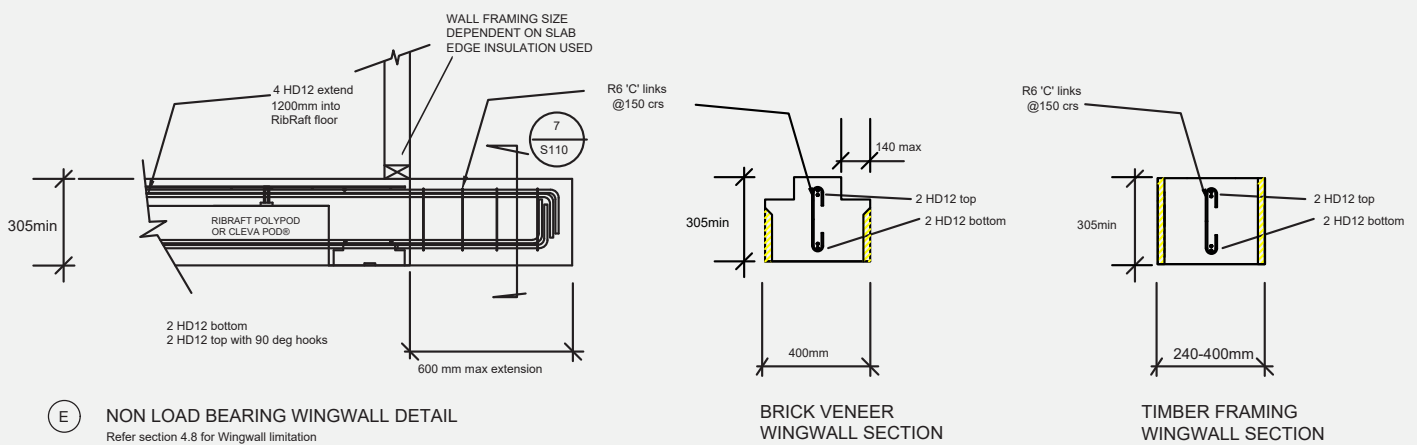
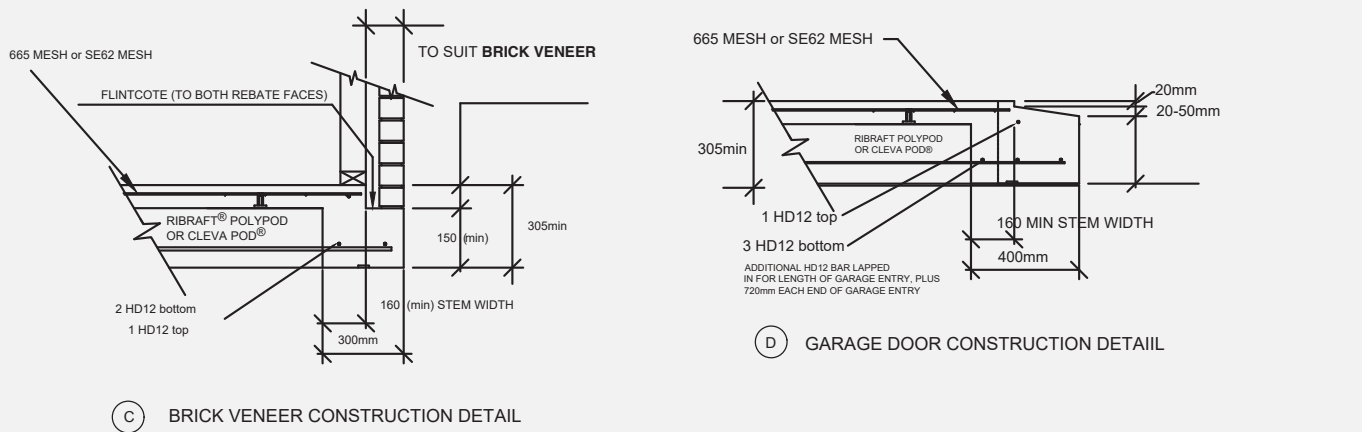

Note: 1. Refer section 4.8 for limitation
 2. Slab edge insulation shown maybe omitted when considered in H1 calculation.

6.9 Step Down Of Up To 600mm In The RibRaft® Floor

Where the site topography requires a step down in the slab, steps of up to 600mm can be accommodated using one of the details provided in Figure 13. A step down in the RibRaft® floor system anchors the floor in that location with respect to volume changes associated with drying shrinkage. As required by 6.4, a free joint shall be provided if the distance from the step down to the slab edge exceeds 15m.

Figure 13. Details where step downs are required in the floor

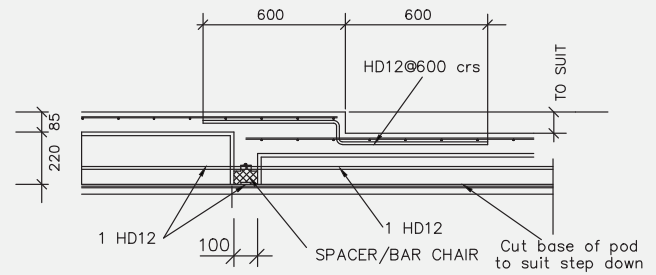

7
S2
SET-DOWN
DETAIL FOR STEP
UP TO 100mm
1:20

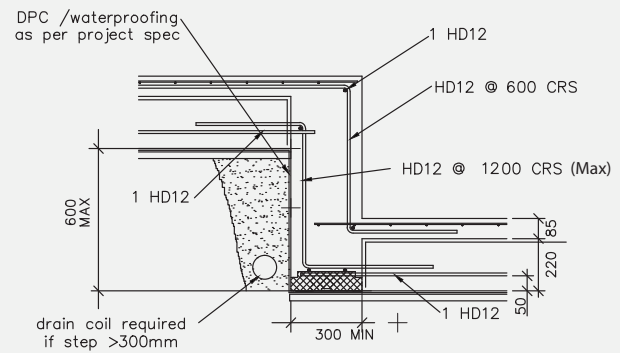

9
S2
SET-DOWN DETAIL
IN CONCRETE
FOR STEP LESS
THAN 600mm
1:20

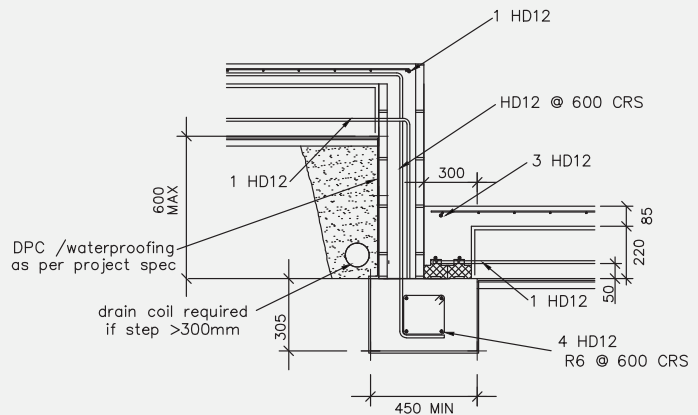

8
S2
SET-DOWN DETAIL
IN MASONRY
FOR STEP LESS
THAN 600mm
1:20

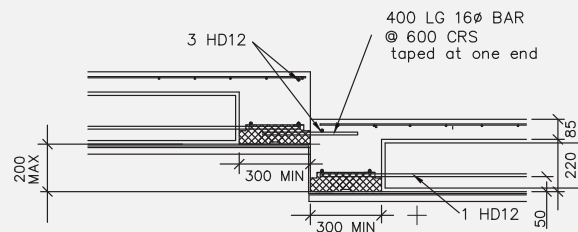

10
S2
SET-DOWN
DETAIL FOR STEP
100 TO 200mm
FOR SEPARATELY
POURED SLABS
1:20

SECTION: INSTALLATION INFORMATION

2

1.0 THIS SECTION DETAILS THE INSTALLATION INFORMATION REQUIRED FOR THE FIRTH RIBRAFT® FLOOR SYSTEM (THE SYSTEM). FULL INFORMATION ON THE DESIGN PROCEDURES AND REQUIREMENTS FOR THE SITE ASSESSMENT ARE DESCRIBED IN SECTION 1 OF THIS MANUAL (DESIGN INFORMATION). WHERE STANDARDS ARE REFERENCED IN THIS MANUAL THESE SHALL INCLUDE THE LATEST AMENDMENTS.



2.0 SITE REQUIREMENTS

2.1 General

The site requirements of this Manual are concerned solely with the soil conditions under or immediately adjacent to the system. If a site does not comply with this Manual, the system shall be subject to specific engineering design.

This Section shall only apply for building sites such that:

- > The ground is as specified in Section 1 of this Manual;
- > Any system erected at the top of a slope (whether fill compacted in accordance with NZS4431, or natural ground) shall be located as shown in Figure 14 so that the finished ground is always outside the dashed line shown. (The vertical distance, V, shall be measured to 50mm below the underside of the slab).

Where the finished ground does not comply with Figure 14, the slope shall be retained by a specifically designed retaining wall.

2.2 Temporary Excavations

No excavation shall take place at a location or in a manner where the stability of the foundation or in a manner where the stability of the foundation is likely to be compromised. The backfilled material shall match the compaction and strength of, and have similar properties to, the surrounding material. The sides of the excavation shall be propped as necessary.

Temporary excavations shall be open for no longer than 48 hours and shall take place only above the critical depth line as shown on Figure 15. Should temporary excavations be required below this line, specific engineering design is required.

2.3 Surface Water

Surface water from the site shall not flow across the slab platform. For example, on cut and fill sites the ground uphill from the system shall be graded to direct any surface run-off away from the system as shown in Figure 16..

Figure 14. Relationship of RibRaft® to Sloping Ground Surface

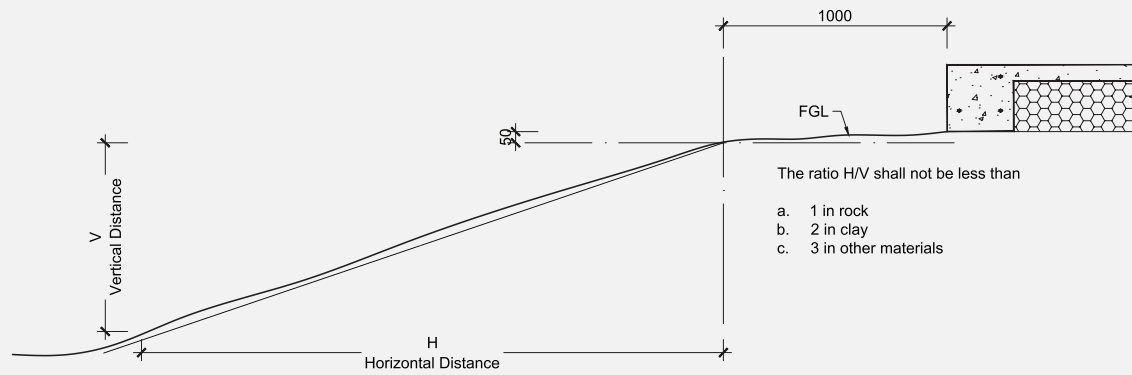

Figure 15. Temporary Excavation Limited

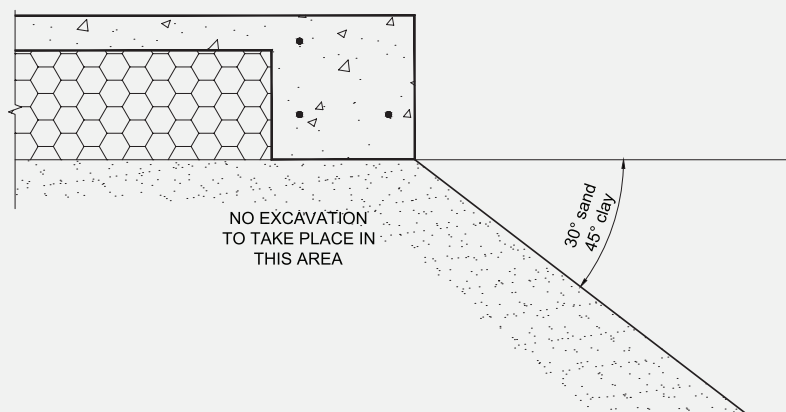
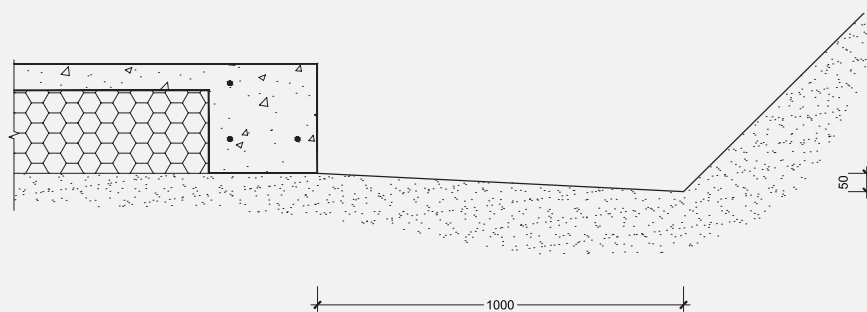

Figure 16. Site Grading



3.0 INSTALLATION PROCEDURE

3.1 Site Preparation

All vegetation, topsoil and other organic or deleterious material shall be removed from the area to be covered by the building (formation area) prior to commencing construction of the system.

3.2 Earthworks

The formation area shall be cut or filled to a level approximately equal to the floor thickness (including insulation layers) plus 25mm below finished floor level. Where fill is required to achieve this level, the fill shall be certified by a geotechnical engineer (outside the scope of this Manual) or shall be granular fill in accordance with Clause 7.5.3 of NZS 3604 "Timber Framed Buildings". The formation area shall also extend a distance equal to the thickness of the fill material beyond the slab perimeter as shown in Figure 4. The installer shall confirm the acceptability of the ground over the entire building platform before proceeding with the construction. Refer to Clause 3.5 of Section 1 (Design Information) for requirements.

Figure 17. Plan of Formation Area

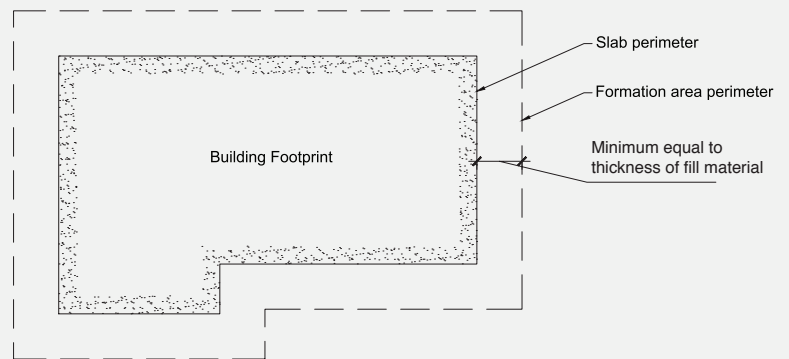

3.3 Shear Keys

Where shear keys are required, the holes shall be drilled following the site clearing and earthworks, in accordance with Clause 4 in this section, and prior to the construction of the system commencing.

3.4 Plumbing and Services

Plumbing and services required beneath the system should preferably be conveyed underground to their plan location then brought up through the system.

The trenching, placing, and bedding of the pipes/ducts and the backfilling of the trenches shall conform to the requirements of the consent documentation. Services shall not run along ribs or edge beams. The maximum diameters of the services shall be as dictated in Clause 6.7 of Section 1.

Where required, the services can be installed by removing unnecessary pods and placing pipes within the pod depth. All pipes shall be held firmly in place and have temporary end covers. Any services crossing ribs or the edge beam horizontally shall be placed only within the middle third of the member. Except as noted in Figure 10 (Section 1) services crossing the ribs vertically shall also be constrained to the middle third of the width of the edge or internal load bearing rib. Except as noted in Figure 10 (section 1) at no stage shall any of the reinforcement bars be relocated or cut to allow for the services (it is acceptable, however to cut the mesh). In some instances this will dictate the location of the ribs. The pods shall be cut to allow for this and if necessary, the spacing of the ribs shall be decreased locally. There shall be 600mm minimum clear spacing in each direction between penetrations through the system.

Where the services pass through the top of the pods, the opening shall be sealed to prevent materials entering the

subfloor cavities. (This can be achieved with Denso tape and a type of easily compressible foam.)

Larger penetrations or voids that are required, up to 450mm square (e.g. for shower waste/traps), shall be installed in accordance with all the conditions of this paragraph. These openings shall be trimmed with 1 HD12 bar (Grade 500N or E) 1500mm long placed along each side of the opening, tied to the mesh. One set of parallel bars shall be placed on top of the mesh and the other set placed under the mesh. These openings shall not be placed over a rib or edge beam. If necessary, the rib spacing shall be reduced or the pod layout altered to ensure that the opening occurs solely in the slab above a pod. Penetrations such as these shall not be installed in garages or other areas where large (>3kN) point loads could be present. Only one penetration greater than 110mm is permitted in the slab above any single pod or part pod. Where two large openings are required to be in close proximity, an internal rib shall separate them. For these large penetrations/voids in the slab, the services shall not be within 25mm of the edges of the void through which they pass, and the opening shall be sealed to prevent materials entering the subfloor cavities. (This type of opening is normally only required for a shower waste/trap and the installation of the shower ensure that the void is sealed/covered).

Where a recess of up to 50mm is required in the topping to provide a rebate for a shower, the construction details shall be as shown in Figure 11 (Section 1).

3.5 Sand Blinding

A layer of sand shall be placed, screeded and compacted over the building platform, extending to the outside edge of the perimeter foundation, refer Figure 18. The maximum thickness of this blinding layer shall be 50mm. The surface shall be level and a minimum of the floor thickness below finished floor level. A small plate compactor, vibrating roller or similar, should be used to compact the sand blinding layer. When the building platform is clay, it is essential that the blinding sand is compacted onto a clay surface that has not been softened by construction activities. If the clay has been softened (i.e. has a muddy surface layer due to construction activities), remove the softened material from under the RibRaft® ribs before placing the sand. If excavation lowers the clay surface to more than 50mm below the underside of the RibRaft®, fill shall be placed in accordance with Clause 7.5.3 of NZS 3604 “Timber Framed Buildings”. The sand is required to be level to ensure that pods or underfloor insulation remain stable throughout the installation of the system.

3.6 Damp Proof Membrane

The damp proof membrane (DPM) material shall be polyethylene sheet in accordance with NZS 3604:2011. The DPM shall be laid over the entire building platform directly on top of the sand blinding layer, extending to the outside of the edge beam - refer Figure 18 below. The joints shall be lapped not less than 150mm and sealed with pressure sensitive tape not less than 50mm wide. All penetrations of the DPM by plumbing and services or punctures during construction shall also be sealed with pressure sensitive tape. The DPM may extend beyond the edge of the slab i.e. underneath the formwork, or may be folded and stapled up the inside of the formwork. The minimum requirement is that the DPM extends to the outside of the edge beam. It is very important that the DPM is not bunched up at the formwork. The installer shall ensure a square and tidy finish at the underside and at all corners of the edge beam.

Figure 18. Sand blinding / DPM / Formwork Details

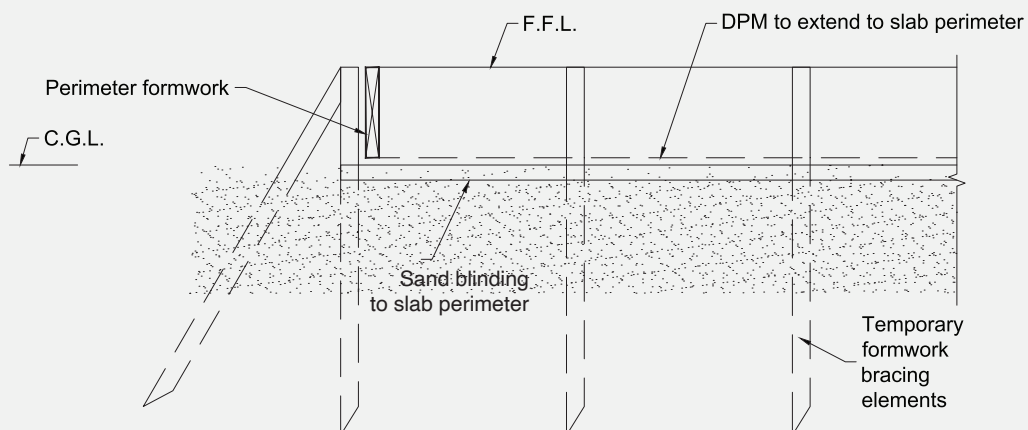

3.7 Edge Formwork

The edge formwork shall be constructed ensuring that the requirements of NZS 3109:1997 “Concrete Construction” are adhered to. The formwork shall be adequately supported and braced to prevent any buckling or warping. If the wall is to be constructed in masonry veneer, formwork for a masonry veneer rebate should be adequately fixed to the perimeter formwork.

Thorough cleaning of re-useable formwork and the use of release agents enhances the life and performance of formwork and maintains a quality surface finish.

3.8 Laying insulation, Pods, HotEdge®, and spacers

Where below pod insulation has been specified on the drawings, lay polystyrene sheets over the entire foot print on the DPM. Butt joint sheets against each other and to the internal face of the formwork or insulation. Cut as necessary to fit.

The Firth RibRaft® polystyrene pods or Cleva pods shall be laid out over the DPM or underfloor polystyrene as appropriate. Where the drawings specify 300mm pods with XPS in ribs, lay 50mm XPS cut to fit in all ribs and beams. Where the drawings specify Firth HotEdge® or HotEdge Extra® and/or HotBase®, install as per Firths literature (refer Firth website). The edge beam shall be formed using the Firth approved 300mm spacers (refer Figure 22). These shall be placed at a maximum of 1200mm centres along the perimeter of the slab and one per pod or part pod. Ribs supporting a load bearing wall shall be formed using a minimum of one Firth approved 300mm spacer along the edge of each pod or part pod.

For the insulation of Cleva Pods® refer to the Cleva Pod installation guide www.clevaco.co.nz

For poly pods, except where a 300mm wide rib is required, each pod or part pod shall always be separated by 100mm using a minimum of one Firth approved 100mm spacer along each edge of each pod or part pod.

The ribs in both directions shall form a waffle pattern throughout the slab. It is essential that the ribs and edge beams are straight when the concrete is poured, i.e. the pods need to be lined up. Figure 19 shows a detailed layout of the pods and spacers.

Where the shape of the house plan dictates, it may be more practical to consider the floor to be made up of different segments. The pods in each segment shall be in a regular waffle pattern – refer right hand side of Figure 20. Where these segments meet, the pods shall be cut to suit and the ribs made to join. The non right-angle rib junctions created by this approach are acceptable.

Alternatively, it is also acceptable to keep the orientation of the pods constant throughout the plan and have non right-angle junctions between the ribs and edge beam – refer left hand side of Figure 20.

As can be seen from Figure 20, it is not necessary for the pods to line up perfectly with the edge beam. It is acceptable to cut the pods (i.e. use part pods).

Firth 100mm spacers and Firth 300mm spacers can not be used with 300mm pods. WJ100 & WJ101 are suitable for both 220 & 300mm pods.

Figure 19. Detailed layout of Pods and spacers (mesh and top steel omitted for clarity)

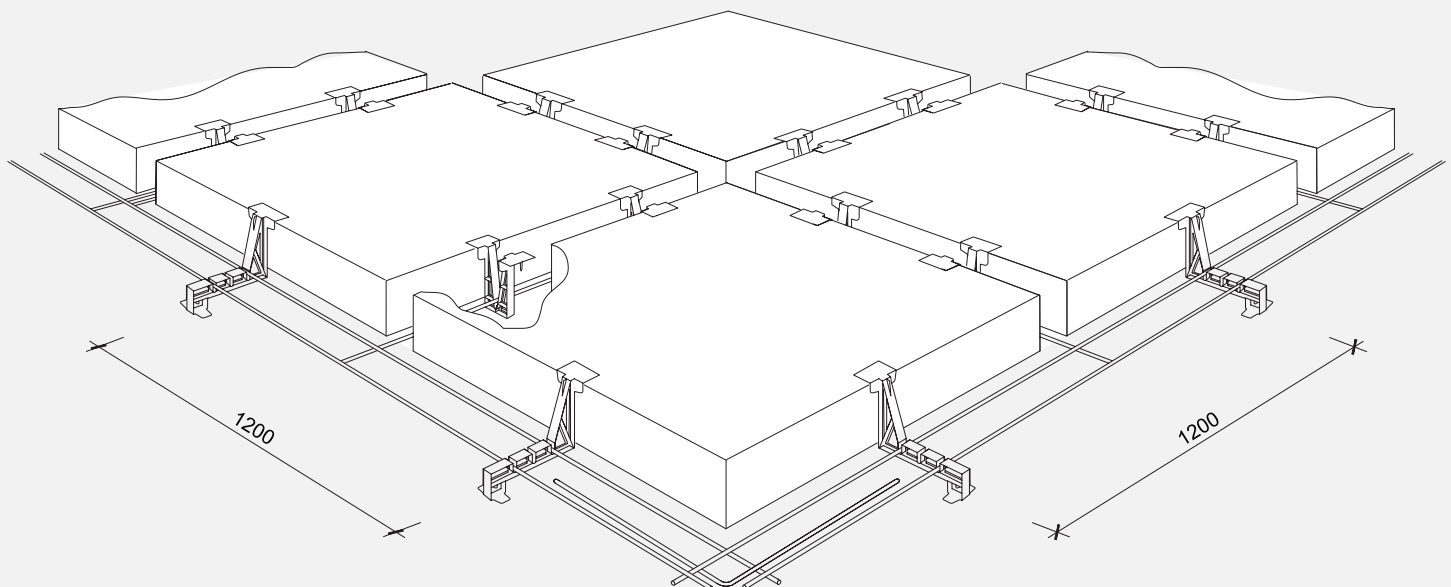

3.9 Reinforcing Steel

Reinforcing bars shall conform to NZS 4671:2019 "Steel Reinforcing Materials". All bars shall be of deformed type (Grade 500N or E). All bends shall be made cold without fracture and in accordance with the bend diameters given in NZS 3109 "Concrete Construction". Welded lap joints are not permitted.

Reinforcing steel in the slab shall consist of Welded Reinforcing Mesh complying with AS/NZS 4671:2019 with a minimum weight of 2.27kg/m, a lower characteristic stress of 500MPa, square configuration of orthogonal bars between 150 to 200mm centres, and ductility class L or E, hereafter referred to as "mesh". The presence of Class 500N or E reinforcing bars in the ribs and beams provides adequate ductility of the system which allow the use of class L mesh. Typically the topping mesh reinforcement will be 665 mesh (class L) or SE62 ductile mesh, each being equally applicable

Figure 19 shows the detailed layout of the spacers and the steel in the edge beam and the standard ribs.

Figure 20. Typical Pod And Rib Layout

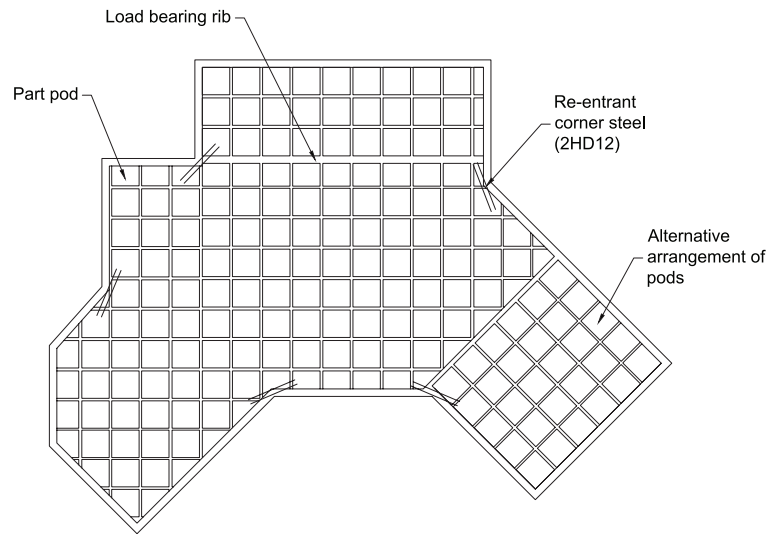
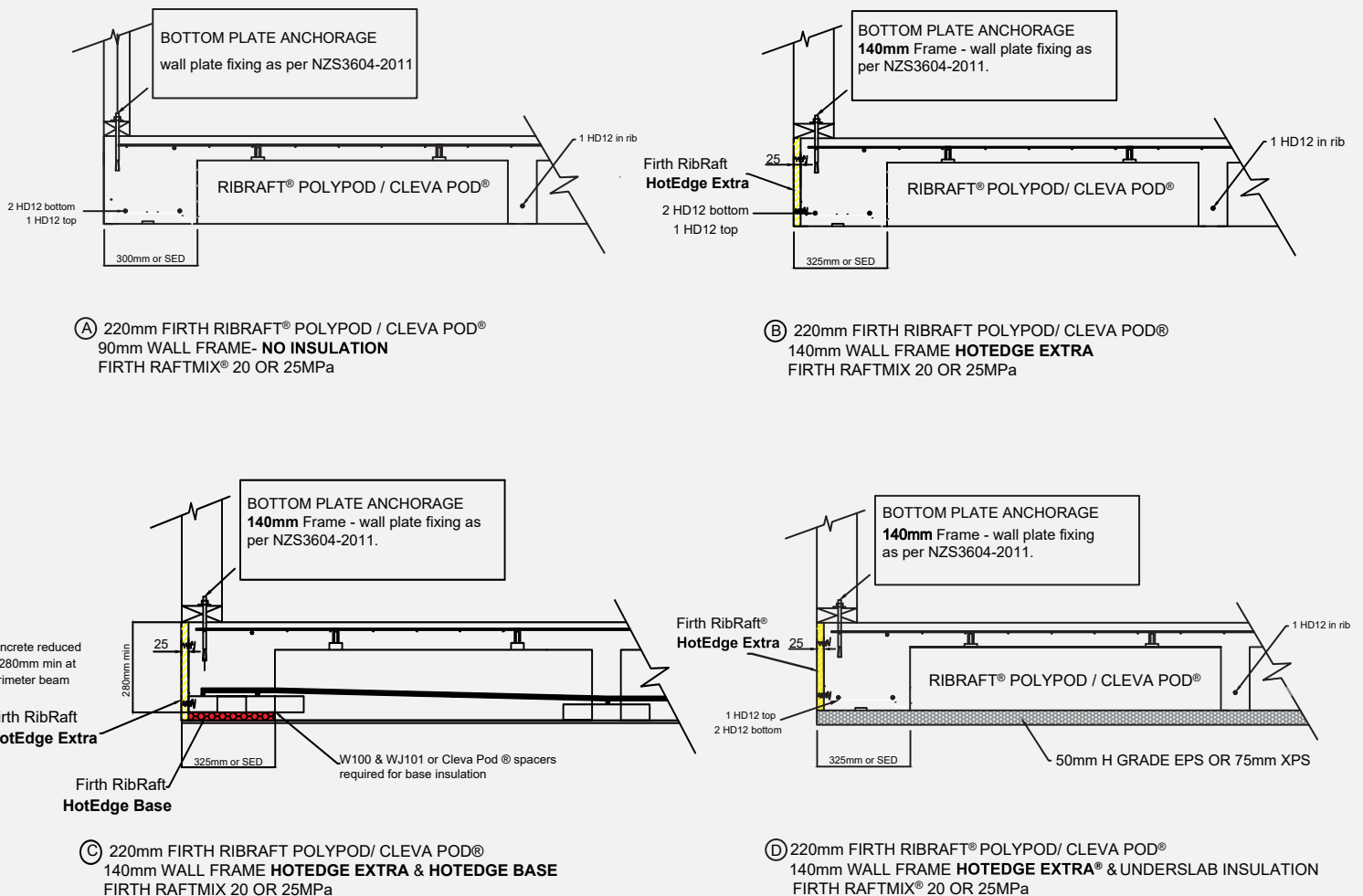

Figure 21.



3.10 Edge Beam Steel

Two edge beam reinforcing bars shall be placed in the bottom of the edge beam and supported in the correct position by the Firth spacers, as shown in Figure 21. One edge beam bar shall be tied below the mesh at the perimeter of the area covered by the polystyrene pods as shown in Figure 21.

All steel shall be lapped a minimum of 60 bar diameters (720mm for 12mm steel). Tying of the edge beam steel is only required at corners. Figure 22 shows the layout for the edge beam bottom steel bars at the corner. The inner bottom bars and the top bars shall cross each other and extend to 75mm from the outside face of the edge beam as shown. These bars shall be tied together where they cross. For solutions using veneer rebates the top bars shall terminate 50mm from the inside face of the rebate and be tied where they cross.

3.11 Rib Steel

Rib reinforcing steel shall be placed in the bottom of the internal ribs and supported in the correct position by approved spacers. Figure 23 shows the spacers, and Figure 19 shows a detailed section identifying how the steel is located in the spacers. The 300mm spacer shall be used for the 300mm wide internal ribs. These spacers ensure that cover to DPM below the base is greater than 45mm and cover to the exterior perimeter is 75mm.

All steel shall be lapped a minimum of 60 bar diameters (720mm for 12mm steel). At junctions with the edge beam, each rib steel bar shall sit on top of the edge beam bars, and extend to the outermost bar. The 75mm cover to the edge of the beam shall still be allowed for. One HD12 bar (Grade 500N or E) shall be placed in the bottom of each 300mm wide rib. For perimeter 300mm ribs a HD12 bar is also required in the top at the beam.

3.12 Mesh Reinforcing

Mesh reinforcing shall be placed over the pods and supported on mesh chairs to achieve minimum concrete cover. At laps the overlap of the outermost cross wires of the sheets shall be the spacing of the wires plus 50mm.

3.13 Re-entrant Corner Steel

Two HD12 bars (Grade 500N or E), 1200mm long tied to the top of the mesh at 200mm centres, with 50mm cover to the internal corner as detailed in Figure 20 (this steel is to help reduce the width of cracks that may develop at this location)

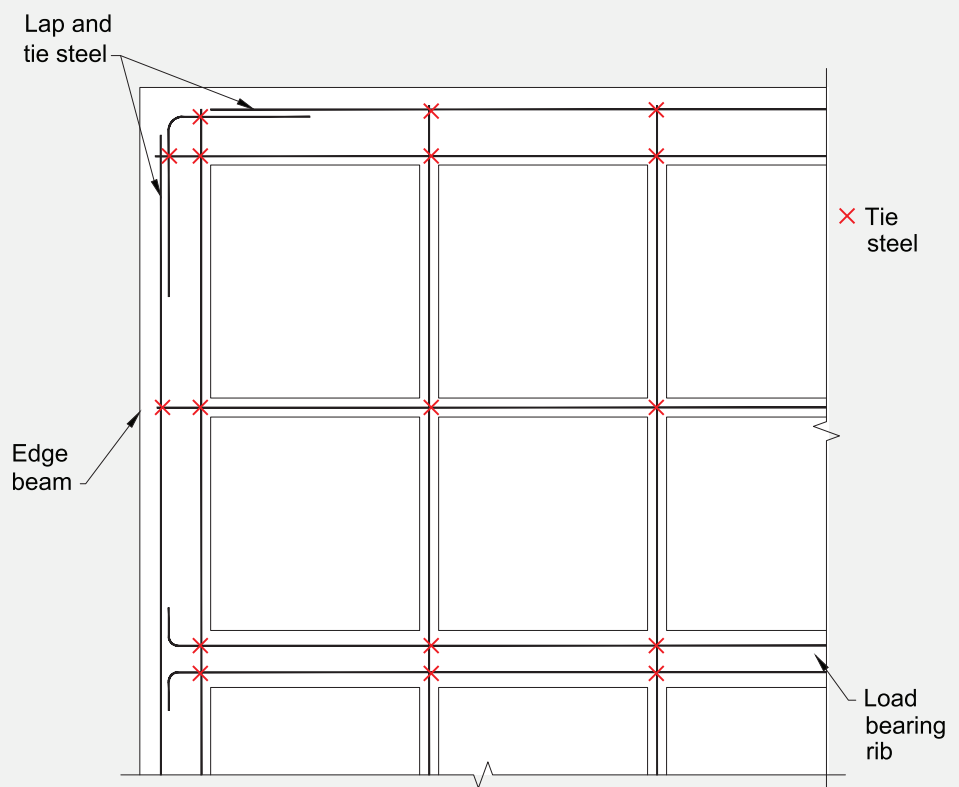

Figure 22. Corner steel layout

3.14 Concrete Installation

To comply with this manual, Firth Certified Concrete® must be used. Concrete placing, finishing and curing shall be in accordance with NZS 3109:1997, Clause 7.

3.15 Placing

Only RaftMix® or RaftMix® 25 concrete supplied by Firth Industries, shall be used in the floor. These two different concrete mixes shall be used in the following instances:

- > RaftMix® - a 20MPa 100mm slump mix available as a pump mix suitable for 100mm pump lines available in either a 13mm or more usually a 19mm nominal aggregate size, or as a structural (non-pump) mix. For Cleva Pod® use Firth 20MPa (mix code: RC2019AW).
- > RaftMix® 25 - a 25MPa 100mm slump mix available as a pump mix suitable for 100mm pump lines available in either a 13mm or more usually a 19mm nominal aggregate size, or as a structural (non-pump) mix. This mix shall be specified for buildings constructed in the 'sea spray zone' (i.e. within 500m of the sea including harbors, within 100m of tidal estuaries or inlets, on offshore islands and elsewhere defined as exposure Zone D in 4.2.3.3 of NZS3604). For Cleva Pod® use Firth 25MPa (mix code: RC2519AW)..
- > Check the drawings for the project. Where the specifier aims to achieve a **lower carbon footprint**, the concrete specification may request an EC rating. These mixes are designed to achieve the specified strength and a maximum specified carbon footprint. When ordering concrete ensure the EC rating is communicated when its specified.

Figure 23. Spacer Details

Firth 300mm Spacer

Use only with 220mm polystyrene pods where HotEdge Base® is not utilised.

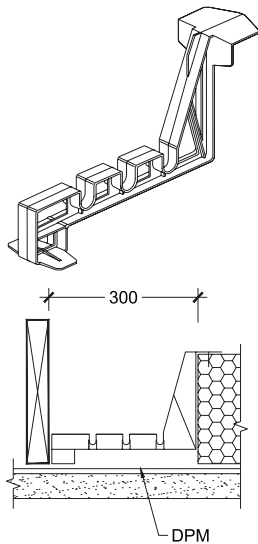

Firth & Cleva Pod® 100mm spacers

Use for 220mm pods

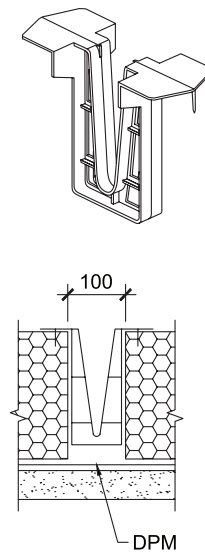

WJ100mm spacer & Cleva Pod® spacer

Use for 220 or 300mm pods or for options using HotEdge Base®. Use a WJ101 extension with WJ100 Spacer when creating a 300mm perimeter beam extension.

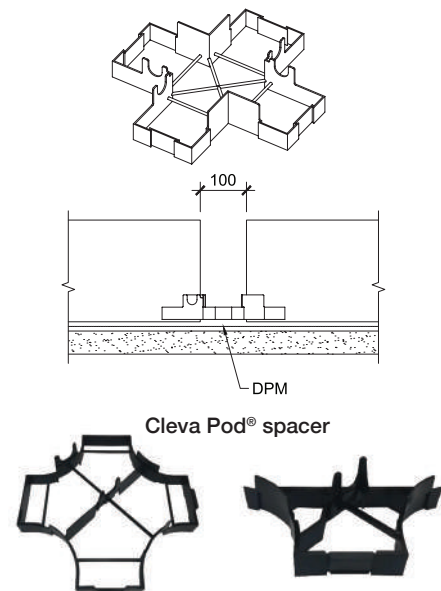

The concrete supplied by Firth shall be poured in such a way to ensure that the pods remain in position during placing (Firth recommends that small amounts of concrete be placed on top of the pods prior to the ribs being filled). The concrete shall be compacted with the use of an immersion vibrator around all steel and into all corners of the formwork.

3.16 Finishing

Screeding with the aid of a level shall commence immediately after compaction. Unless specifically installed as a screeding datum, the top of the formwork shall not be assumed as level and thus shall not be used for screeding purposes. Final finishing with a trowel shall take place after all the bleed water has evaporated. The edge of the slab and rebates shall be tooled to prevent chipping of the top of the slab.

Early age care of the slab shall be in accordance with good trade practice appropriate for the weather conditions - refer CCANZ website sections if further guidance is required:

www.ccanz.org.nz/page/Early-Age-Crack-Control.aspx
www.ccanz.org.nz/page/Hot-and-Cold-Weather-Concreting.aspx

Early Age Crack Control
 Hot and Cold Weather Concreting

The surface shall be a blemish-free surface to class U3 finish (Refer NZS 3114:1987 "Specification for Concrete Finishes").

3.17 Curing

Proper curing of the concrete must take place immediately after finishing the concrete. One of the following methods of curing is recommended:

- > Ponding or continuous sprinkling of water.
- > Placing a wet covering or plastic membrane over the slab.
- > The use of liquid membrane curing compounds. However if these are used, they must be compatible with any subsequent applied surfacing.

3.18 Shrinkage Control Joints

Shrinkage control joints reduce the risk of unwanted cracks, and their placement needs to be carefully considered where uncontrolled cracking could be unacceptable. Two types are described here: saw cut joints (which are tied joints), and free joints.

3.19 Saw Cut Joints

Saw cuts are located at positions in which the concrete is likely to crack due to stresses induced by restrained shrinkage. The aim of providing them is for the concrete to crack at the bottom of the saw cut thus minimizing the potential for a visible crack wandering over the surface. The level of reinforcement provided in a RibRaft® means that cracks have no structural implications being only an aesthetics issue. Factors to consider are the type of floor finish, the location of ribs and ground beams, underfloor heating and the effect of piles restraining shrinkage.

When warm sunny days are followed by cool nights, the change in temperature can cause cracking. Hence preference should be given to using early entry saws which are used immediately after finishing. Shrinkage control joints cut using diamond blades shall be cut as early as possible which is typically within 24 hours of hardening in summer, and 48 hours in winter.

They shall be cut to a depth of 25mm. Shrinkage control joints do not guarantee to eliminate all visible or unwanted cracks.

Joints shall be positioned to coincide with major changes in floor plan. Where concrete is to be exposed, for example in a garage, or brittle covering placed over, the maximum intermediate bay sizes shall be limited to 5m. Bay dimensions formed by shrinkage control joints shall be limited to a maximum ratio of length:width of 1.5:1. Shrinkage control joints shall be placed over 100mm wide internal ribs wherever possible. Where a shrinkage control joint runs along the line of a 300mm wide load bearing rib, then the joint shall be located directly above one edge of that rib.

In order to limit the width of cracks at re-entrant, or internal corners, extra steel shall be placed on top of the mesh. These shall be 2-HD12 bars (grade 500N or E), 1200mm long tied to the top of the mesh at 200mm centres, with 50mm cover to the internal corner - refer Figure 20.

3.20 Free Joints

Where the length of the floor exceeds 30m a free joint shall be provided as detailed in Section 1, Figure 8. Movement, shrinkage and thermal, will occur over this joint so it shall be positioned to minimize the impact of this movement on floor coverings and wall elements.

Where the bottom of the RibRaft® is not flat (for example the floor incorporates a step down), free joints shall be provided if the distance from the step down to edge of slab exceeds 15m.

3.21 Removal of Formwork

The formwork shall not be removed prior to 12 hours after the slab has been finished. No installation loads are to be placed on the system before adequate curing has taken place.

3.22 Masonry Veneer

Where the building is to be clad with masonry veneer, the rebate in the edge beam shall be waterproofed with a bituminous sealer due to the possibility of ponding of water. Firth recommends a Flintcote® or equivalent coating on both the vertical and horizontal faces of the rebate.

3.23 Landscaping/Paving

Landscaping and/or paving adjacent to the slab shall be kept as a minimum the specified distance below finished floor level as required by NZS 3604. The landscaping shall allow for large trees to be kept sufficiently away from the edge of the slab. This is to prevent the tree roots from disturbing the soil moisture conditions under the slab. As a guide, trees should be as far away from the edge of the slab as they are tall when fully grown.

The building owner shall ensure that the ground surrounding the system is maintained so that the integrity of the system is not jeopardised. In other words, at no time shall the ground immediately adjacent to the system be allowed to settle away to expose the underside of the slab.

3.24 Ongoing Maintenance

4.0 SHEAR KEYS

Shear keys, if required, shall be provided to conform to the requirements of Section 1 of this Manual. Holes for the shear keys shall be drilled at least 1000mm deep. Into the bottom of each hole a RibRaft® Shear Key Support shall be placed. Every precaution shall be taken to ensure that the shear key support is laid level and at the base of the hole. The minimum depth of concrete placed on the support shall be 900mm. Refer to Figure 11 for construction details.

The connection steel (2HD12 Grade 500N or E) shall be secured in place and held during pouring to ensure the bars are correctly located. The concrete for the shear keys can be placed separately to the rest of the floor and shall be finished level to the top of the sand blinding layer, or poured in one pour with the RibRaft® floor. If poured separately the top surface of the shear key shall be finished rough to ensure a good join to the Firth Raftmix concrete in the system and the DPM shall be neatly cut around the shear keys.

Figure 24. Shear Pile Construction Detail

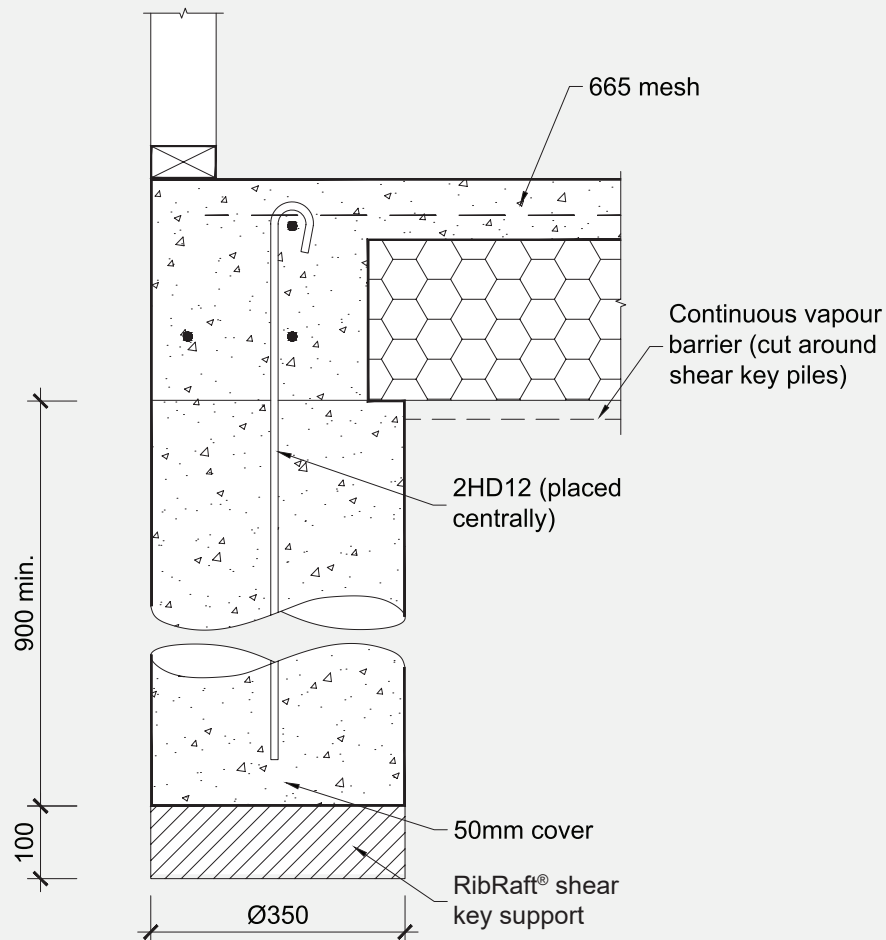

SECTION: VERIFICATION

3

1.0 DESIGN

Verification that the design complies with the structural limitation outlined in this Manual is the responsibility of the designer, and shall be confirmed by the Building Consent Authority issuing the Building Consent. Solutions outside the limitations outlined in this Manual will require specific engineering design.

2.0 CONSTRUCTION

The RibRaft® foundation system has been designed to accommodate structures complying with the **non specific design standards NZS3604 or NZS4229**. With these types of structures the Building Consent Authority specifies the inspections required and often conducts these. A similar construction verification process shall be applied to the RibRaft® system.

To assist inspection the following check list has been prepared for structures complying with the limitation:

PRE-LAYOUT INSPECTION CHECK LIST

- GOOD GROUND CONFIRMED AS PER NZS3604, CLAUSE 3.1.3. OR SCALA OR SHEAR VANES TESTS CONFIRM ADEQUATE BEARING CAPACITY.
- VEGETATION, TOPSOIL, ORGANIC OR DELETERIOUS MATERIAL REMOVED.
- PROXIMITY TO SLOPE-GROUND SURFACE IS ALWAYS ABOVE DASH LINE SHOWN IN FIGURE 1.
- SHEAR PILES (WHERE REQUIRED) IN PLACE AND REINFORCEMENT PROTRUDING.
- FORMATION AREA EXTENDS AT LEAST THE DEPTH OF GRANULAR FILL BEYOND BUILDING FOOTPRINT.
- STEPS IN THE FORMATION ARE DETAILED IN ACCORDANCE WITH THIS MANUAL.

Figure 25. Relationship of RibRaft® To Sloping Ground Surface

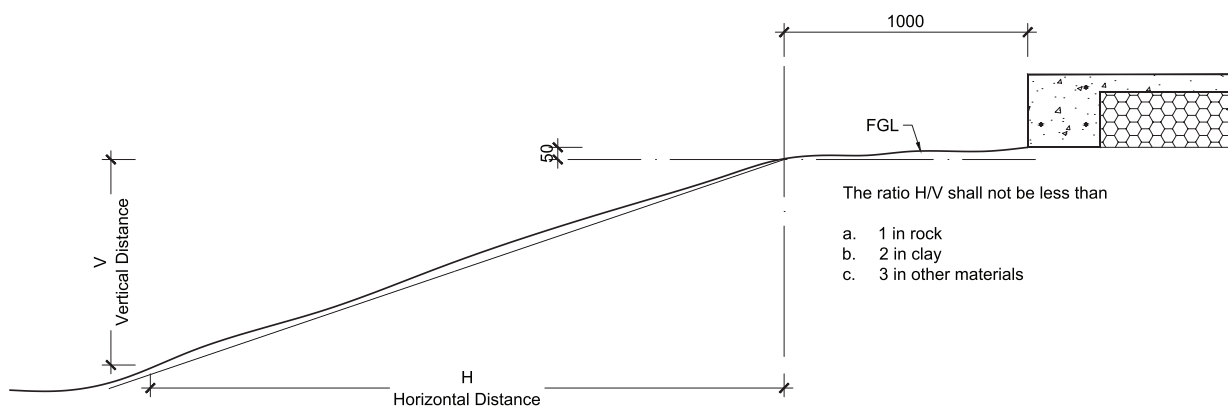

PRE POUR INSPECTION CHECK LIST

PERIMETER FOUNDATION	<input type="checkbox"/> WIDTH 300MM ⁽¹⁾
	<input type="checkbox"/> REINFORCEMENT 2 X HD12 BOTTOM, 1 X HD12 TOP
	<input type="checkbox"/> FIRTH SUPPLIED SPACER USED AT 1.2M MAXIMUM CENTRES
	<input type="checkbox"/> HOTEDGE®, HOTEDGE EXTRA® OR HOTEDGE BASE® INSULATION INSTALLED AS SPECIFIED
INTERNAL RIBS	<input type="checkbox"/> WIDTH 100MM
	<input type="checkbox"/> REINFORCEMENT 1 X HD12
	<input type="checkbox"/> FIRTH SUPPLIED SPACER, MAX SPACING OF ONE PER POD OR PART POD
LOAD BEARING RIBS	<input type="checkbox"/> WIDTH 300MM
	<input type="checkbox"/> REINFORCEMENT 2 X HD12 BOTTOM
	<input type="checkbox"/> FIRTH SUPPLIED SPACER, MAX SPACING OF ONE PER POD OR PART POD
PODS	<input type="checkbox"/> FIRTH SUPPLIED RIBRAFT® POD OR CLEVA PODS®
MESH	<input type="checkbox"/> MESH CHAIRS 1.2M MAX CENTRES, MIN TWO PER POD OR ONE PER PART POD
	<input type="checkbox"/> MESH IN PLACE AND 665 OR SE62
	<input type="checkbox"/> MESH LAPS OVERLAP OF OUTERMOST CROSSWIRE = MESH SPACING + 50MM
REINFORCEMENT	<input type="checkbox"/> 2 X HD12 BARS 1.2M LONG PROVIDED AT RE-ENTRANT CORNERS
	<input type="checkbox"/> LAPS FOR 12MM REINFORCEMENT MINIMUM OF 720MM
CONCRETE	<input type="checkbox"/> COVER PODS TO MINIMUM OF 85MM OR 110MM IF IN FLOOR HEATING
	<input type="checkbox"/> USED FIRTH RAFTMIX® ORDERED
SERVICE PENETRATIONS	<input type="checkbox"/> NO REINFORCEMENT (WITH EXCEPTION OF MESH) CUT TO ALLOW PASSAGE OF SERVICE PIPES. REFER CLAUSE 6.3 OF SECTION 1 FOR EXCEPTIONS
	<input type="checkbox"/> PIPES WRAPPED WITH MINIMUM 6MM THICKNESS OF IMPERMEABLE COMPRESSIBLE MATERIAL WHERE IN CONTACT WITH CONCRETE
	<input type="checkbox"/> DIAMETER/SIZE OF PENETRATIONS AS PER TABLE 6, SECTION 1 OF THIS MANUAL

(1) At locations of service penetrations the width of the perimeter foundation maybe locally increased. Refer Figure 14 Section 1 for details.



CONCRETE & MASONRY PRODUCTS: A SUSTAINABLE BUILDING OPTION & SOLUTION

- ✓ Environmentally compliant manufacturing plants
- ✓ Surplus water and some aggregates recycled
- ✓ Low transport impacts
- ✓ Leftover concrete returned from construction sites
- ✓ Passive solar heated thermal mass makes completed buildings more energy-efficient
- ✓ Most wash water returned from construction sites
- ✓ Highly durable, low maintenance buildings and no rot
- ✓ High degree of noise control
- ✓ Inherent fire resistance
- ✓ Overall longer effective building life
- ✓ Demolished concrete can be recycled as hard fill or aggregate

© Firth Industries 2023. All rights reserved. Content in this document is protected under the Copyright Act 1994. No material may be reproduced in whole or in part without the written consent of the copyright holder.



0800 FIRTH 1 (347841)
FIRTH.CO.NZ

FR-TECH-20230809